

EVERLAST

SUPERULTRA 206i

MOSFET DC Multi-Process Tig/Stick/Plasma Cutter *



Operator's Manual For The DC Output SuperUltra 206i Safety, Setup and General Use Guide

***Not suitable for welding aluminum. Does not weld AC.**

everlastwelders.com



1-877-755-9353

329 Littlefield Ave. South San Francisco, CA 94080 USA

Rev. 1 0 01010-16

Specifications and Accessories subject to change without notice.

TABLE OF CONTENTS

Section.....	Page
Letter to the Customer	3
Everlast Contact Information.....	4
Safety Precautions.....	5
Introduction and Specifications.....	9
Unit Specifications.....	10
General Overview.....	11
General Use and Care.....	11
Quick Setup Guide, TIG Torch/Cooler Connection	12
Quick Setup Guide, Plasma Connection.....	13
Quick Setup Guide, Stick Polarity and Connection	14
Quick Setup Guide, Rear Connection for Plasma...	15
Quick Setup Guide, Rear Connection for TIG.....	16
Front Panel Features and Controls.....	17
Rear Panel Features and Controls.....	19
Tungsten Preparation.....	21
Polarity, Tungsten and Amp Recommendations....	22
High Frequency Start TIG Operation.....	23
Stick Arc Starting Procedure.....	24
Plasma Function and Operation.....	25
Expanded View of TIG torch.....	30
Expanded View of AG60 Plasma Torch.....	31
7 Pin Connector Pin-out.....	32
Troubleshooting.....	33

NOTE: Product Specifications and features are subject to change without notice. While every attempt has been made to provide the most accurate and current information possible at the time of publication, this manual is intended to be a general guide and not intended to be exhaustive in its content regarding safety, welding, or the operation/maintenance of this unit. Everlast Power Equipment INC. does not guarantee the accuracy, completeness, authority or authenticity of the information contained within this manual. The owner of this product assumes all liability for its use and maintenance. Everlast Power Equipment INC. does not warrant this product or this document for fitness for any particular purpose, for performance/accuracy or for suitability of application. Furthermore, Everlast Power Equipment INC. does not accept liability for injury or damages, consequential or incidental, resulting from the use of this product or resulting from the content found in this document or accept claims by a third party of such liability.

Dear Customer,

THANKS! You had a choice, and you bought an Everlast. We appreciate you as a customer and hope that you will enjoy years of use from your welder.

Please go directly to the Everlast website to register your unit and receive your warranty information. Your unit registration is important should any information such as product updates or recalls be issued. It is also important so that we may track your satisfaction with Everlast products and services. If you are unable to register by website, contact Everlast directly through the sales department through the main customer service number in your country. Your unit will be registered and warranty will be issued and in full effect. Keep all information regarding your purchase. **In the event of a problem you must contact technical support before your welder can be a candidate for warranty service and returned.**

Please review the current online warranty statement and information found on the website of the Everlast division located in or nearest to your country. Print it for your records and become familiar of its terms and conditions. At the time of this manual printing the MOSFET based SuperUltra 206i, 206Pi, have a 3 year warranty in the United States. See the Everlast website, www.everlastgenerators.com for complete details. Accessories are covered under a separate warranty which may vary in length.

Everlast offers full technical support, in several different forms. We have online support available through email, and a welding support forum designed for customers and noncustomer interaction. Technical advisors are active on the forum daily. We also divide our support into two divisions: technical and welding performance. Should you have an issue or question concerning your unit, please contact performance/technical support available through the main company headquarters available in your country. For best service, call the appropriate support line and follow up with an email, particularly during off hours, or in the event you cannot reach a live person. In the event you do not reach a live person, as is likely during heavy call volume times, holidays, and off hours, leave a message and your call will be returned normally, within 24 hours. Also, for quick answers to your basic questions, join the company owned forum available through the website. You'll find knowledgeable, helpful people and staff available to answer your questions, and perhaps find a topic that already addresses your question at <http://www.everlastgenerators.com/forums/>.

Should you need to call or write, always know your model name, purchase date and welder manufacturing inspection date. This will assure the quick and accurate customer service. **REMEMBER: Be as specific and informed as possible. Technical and performance advisors rely upon you to carefully describe the conditions and circumstances of your problem or question. Take notes of any issues as best you can. You may be asked many questions by the advisors to clarify problems or issues that may seem very basic. However, diagnosis procedures MUST be followed to begin the warranty process. You must receive an Return Authorization number before returning your unit to Everlast for Repair. Repairs made by un-authorized repair centers are not reimbursable under the warranty agreement.**

Please, keep in mind that our technical advisors can't assume anything diagnosing the unit, even with experienced users, and must cover all aspects to properly diagnose the problem. The advisor must start at a basic level diagnosis before proceeding to more complex issues. Full cooperation during the diagnoses will help insure you have the most accurate and helpful diagnosis possible. In many cases, it may even result in a remedy over the phone. Depending upon your issue, it is advisable to have basic tools handy such as screwdrivers, wrenches, pliers, and even an inexpensive test meter with volt/ohm functions before you call.

Let us know how we may be of service to you if you have any questions or problems.

Sincerely,

Everlast Customer Service



Serial number: _____
Model number: _____
Date of Purchase _____

Contact Information

Everlast US:

Everlast consumer satisfaction email: sales@everlastwelders.com
Everlast Website: everlastwelders.com
Everlast Technical Support: support@everlastwelders.com
Everlast Support Forum: <http://www.everlastgenerators.com/forums/index.php>
Main toll free number: 1-877-755 WELD (9353) 9am—5pm PST M-F
11am-4pm PST Sat.

FAX: 1-650-588-8817

Everlast Canada:

Everlast consumer satisfaction email: sales@everlastwelders.ca
Everlast Website: everlastwelders.ca
Everlast Technical Support: sales@everlastwelders.ca
Telephone: 905-637-1637 9am-4:30pm EST M-F
10am-1pm EST Sat.

FAX: 1-905-639-2817

Everlast Australia:

Sydney: 5A Karloo Parade Newport NSW 2106
(02) 9999 2949
Port Macquarie: 2B Pandorea Place Port Macquarie
(02) 8209 3389
After hours support: 0413 447 492
Everlast Technical Support: support@pickproducts.com

SAFETY PRECAUTIONS

Everlast is dedicated to providing you with the best possible equipment and service to meet the demanding jobs that you have. We want to go beyond delivering a satisfactory product to you. That is the reason we offer technical support to assist you with your needs should an occasion occur. With proper use and care your product should deliver years of trouble free service.



REMEMBER: Safe operation and proper maintenance is your responsibility!

We have compiled this operator's manual, to instruct you in basic safety, operation and maintenance of your Everlast product to give you the best possible experience. Much of welding and cutting is based upon experience and common sense. As thorough as this welding manual may be, it is no substitute for either. Exercise extreme caution and care in all activities related to welding or cutting. This manual cannot Your safety, health and even life depends upon it. While accidents are never planned, preventing an accident requires careful planning. **Please carefully read this manual before you operate your Everlast unit.** This manual is not only for the use of the machine, but to assist in obtaining the best performance out of your unit. Do not operate the unit until you have read this manual and you are thoroughly familiar with the safe operation of the unit. If you feel you need more information please contact Everlast Support.

The warranty does not cover improper use, maintenance or consumables. **Do not attempt to alter or defeat any piece or part of your unit, particularly any safety device.** Keep all shields and covers in place during operation in the unlikely event that a failure of internal components results in sparks or exploding components such as a capacitor failure. If a failure occurs, discontinue further use until malfunctioning parts or accessories have been repaired or replaced by qualified personnel.



Note on High Frequency electromagnetic disturbances:

Certain welding and cutting processes generate High Frequency (HF) waves. These waves may disturb sensitive electronic equipment such as televisions, radios, computers, cell phones, and related equipment. High Frequency may also interfere with fluorescent lights. Consult with a ***licensed*** electrician if disturbance is noted. Sometimes, improper wire routing or poor shielding may be the cause.



HF can interfere with pacemakers. See EMF warnings in following safety section for further information. Always consult your physician before entering an area known to have welding or cutting equipment if you have a pacemaker.

SAFETY PRECAUTIONS



These safety precautions are for protection of safety and health. Failure to follow these guidelines may result in serious injury or death. Be careful to read and follow all cautions and warnings. Protect yourself and others.



Welding and cutting processes produce high levels of ultraviolet (UV) radiation that can cause severe skin burn and damage. There are other potential hazards involved with welding such as severe burns and respiratory related illnesses. Therefore observe the following to minimize potential accidents and injury:



Use appropriate safety glasses with wrap around shields while in the work area, even under welding helmets to protect your eyes from flying sparks and debris. When chipping slag or grinding, goggles and face shields may be required.



When welding or cutting, always use an approved shielding device, with the correct shade of filter installed. Always use a welding helmet in good condition. Discard any broken or cracked filters or helmets. Using broken or cracked filters or helmets can cause severe eye injury and burn. Filter shades of no less than shade 5 for cutting and no less than shade 9 for welding are highly recommended. Shades greater than 9 may be required for high amperage welds. Keep filter lenses clean and clear for maximum visibility. It is also advisable to consult with your eye doctor should you wear contacts for corrective vision before you wear them while welding.



Do not allow personnel to watch or observe the welding or cutting operation unless fully protected by a filter screen, protective curtains or equivalent protective equipment. If no protection is available, exclude them from the work area. Even brief exposure to the rays from the welding arc can damage unprotected eyes.



Always wear hearing protection because welding and cutting can be extremely noisy. Ear protection is necessary to prevent hearing loss. Even prolonged low levels of noise has been known to create long term hearing damage. Hearing protection also further protects against hot sparks and debris from entering the ear canal and doing harm.



Always wear personal protective clothing. Flame proof clothing is required at all times. Sparks and hot metal can lodge in pockets, hems and cuffs. Make sure loose clothing is tucked in neatly. Leather aprons and jackets are recommended. Suitable welding jackets and coats may be purchased made from fire proof material from welding supply stores. Discard any burned or frayed clothing. Keep clothing away from oil, grease and flammable liquids.



Leather boots or steel toed leather boots with rubber bottoms are required for adequate foot protection. Canvas, polyester and other man made materials often found in shoes will either burn or melt. Rubber or other non conductive soles are necessary to help protect from electrical shock.



Flame proof and insulated gauntlet gloves are required whether welding or cutting or handling metal. Simple work gloves for the garden or chore work are not sufficient. Gauntlet type welding gloves are available from your local welding supply companies. Never attempt to weld with out gloves. Welding with out gloves can result in serious burns and electrical shock. If your hand or body parts comes into contact with the arc of a plasma cutter or welder, instant and serious burns will occur. Proper hand protection is required at all times when working with welding or cutting machines!

SAFETY PRECAUTIONS



WARNING! Persons with pacemakers should not weld, cut or be in the welding area until they consult with their physician. Some pacemakers are sensitive to EMF radiation and could severely malfunction while welding or while being in the vicinity of someone welding. *Serious injury or death may occur!*



Welding and plasma cutting processes generate electro-magnetic fields and radiation. While the effects of EMF radiation are not known, it is suspected that there may be some harm from long term exposure to electromagnetic fields. Therefore, certain precautions should be taken to minimize exposure:

- Lay welding leads and lines neatly away from the body.
- Never coil cables around the body.
- Secure cables with tape if necessary to keep from the body.
- Keep all cables and leads on the same side the body.
- Never stand between cables or leads.
- Keep as far away from the power source (welder) as possible while welding.
- Never stand between the ground clamp and the torch.
- Keep the ground clamp grounded as close to the weld or cut as possible.



Welding and cutting processes pose certain inhalation risks. Be sure to follow any guidelines from your chosen consumable and electrode suppliers regarding possible need for respiratory equipment while welding or cutting. Always weld with adequate ventilation. Never weld in closed rooms or confined spaces. Fumes and gases released while welding or cutting may be poisonous. Take precautions at all times.

Any burning of the eyes, nose or throat are signs that you need to increase ventilation.

- Stop immediately and relocate work if necessary until adequate ventilation is obtained.
- Stop work completely and seek medical help if irritation and discomfort persists.



WARNING! Do not weld on galvanized steel, stainless steel, beryllium, titanium, copper, cadmium, lead or zinc without proper respiratory equipment and or ventilation.



WARNING! This product when used for welding or cutting produces fumes and gases which contains chemicals known to the State of California to cause birth defects and in some cases cancer.

(California Safety and Health Code §25249.5 *et seq.*)



WARNING! Do not weld or cut around Chlorinated solvents or degreasing areas. Release of Phosgene gas can be deadly. Consider all chemicals to have potential deadly results if welded on or near metal containing residual amounts of chemicals.



Keep all cylinders upright and chained to a wall or appropriate holding pen. Certain regulations regarding high pressure cylinders can be obtained from OSHA or local regulatory agency. Consult also with your welding supply company in your area for further recommendations. The regulatory changes are frequent so keep informed.



All cylinders have a potential explosion hazard. When not in use, keep capped and closed. Store chained so that overturn is not likely. Transporting cylinders incorrectly can lead to an explosion. Do not attempt to adapt regulators to fit cylinders. Do not use faulty regulators. Do not allow cylinders to come into contact with work piece or work. Do not weld or strike arcs on cylinders. Keep cylinders away from direct heat, flame and sparks.

SAFETY PRECAUTIONS

continued



WARNING! Electrical shock can kill. Make sure all electrical equipment is properly grounded. Do not use frayed, cut or otherwise damaged cables and leads. Do not stand, lean or rest on ground clamp. Do not stand in water or damp areas while welding or cutting. Keep work surface dry. Do not use welder or plasma cutter in the rain or in extremely humid conditions. Use dry rubber soled shoes and dry gloves when welding or cutting to insulate against electrical shock. Turn machine on or off only with gloved hand. Keep all parts of the body insulated from work, and work tables. Keep away from direct contact with skin against work. If tight or close quarters necessitates standing or resting on work piece, insulate with dry boards and rubber mats designed to insulate the body from direct contact.



All work cables, leads, and hoses pose trip hazards. Be aware of their location and make sure all personnel in area are advised of their location. Taping or securing cables with appropriate restraints can help reduce trips and falls.



WARNING! Fire and explosions are real risks while welding or cutting. Always keep fire extinguishers close by and additionally a water hose or bucket of sand. Periodically check work area for smoldering embers or smoke. It is a good idea to have someone help watch for possible fires while you are welding. Sparks and hot metal may travel a long distance. They may go into cracks in walls and floors and start a fire that would not be immediately visible. Here are some things you can do to reduce the possibility of fire or explosion:

- Keep all combustible materials including rags and spare clothing away from area.
- Keep all flammable fuels and liquids stored separately from work area.
- Visually inspect work area when job is completed for the slightest traces of smoke or embers.
- If welding or cutting outside, make sure you are in a cleared off area, free from dry tender and debris that might start a forest or grass fire.
- Do not weld on tanks, drums or barrels that are closed, pressurized or anything that held flammable liquid or material.



Metal is hot after welding or cutting! Always use gloves and or tongs when handling hot pieces of metal. Remember to place hot metal on fire-proof surfaces after handling. Serious burns and injury can result if material is improperly handled.



WARNING! Faulty or poorly maintained equipment can cause injury or death. Proper maintenance is your responsibility. Make sure all equipment is properly maintained and serviced by qualified personnel. Do not abuse or misuse equipment.



Keep all covers in place. A faulty machine may shoot sparks or may have exploding parts. Touching uncovered parts inside machine can cause discharge of high amounts of electricity. **Do not allow employees to operate poorly serviced equipment.** Always check condition of equipment thoroughly before start up. Disconnect unit from power source before any service attempt is made and for long term storage or electrical storms.



Further information can be obtained from The American Welding Society (AWS) that relates directly to safe welding and plasma cutting. Additionally, your local welding supply company may have additional pamphlets available concerning their products. Do not operate machinery until your are comfortable with proper operation and are able to assume inherent risks of cutting or welding.



Argon and Air Regulator



26 series TIG torch



Stick Electrode Holder



Work Clamp



AG60 Plasma Torch



Foot Pedal Assembly



Consumable Starter Kit

NOTE: Accessory and consumable style and quantities are subject to change without notice. Consumable starter kits provide only enough consumables to get started. No tungsten is provided. Extra consumables and full consumable kits may be purchased through Everlast or almost any local welding supply store for TIG. Plasma cutting consumables may be bought direct from Everlast or other online retailers.

SUPERULTRA 206i INPUT/OUTPUT SPECIFICATIONS

FEATURE/SPECIFICATION	SUPERULTRA 206i
INVERTER TYPE	MOSFET
INPUT VOLTAGE $\pm 10\%$; PHASE/FREQUENCY	120/240V; 1PH/50-60Hz
MAXIMUM INPUT AMPS ($I_{1,MAX}$), Inrush.	30A @120V/ 28A @ 240V
MAXIMUM INPUT RUNNING AMPS ($I_{1,eff}$), Rated.	18A @ 120V/ 17 A @ 240V
DUTY CYCLE % @ AMPS	TIG: [120V] 35%@125A/15V 60%@ 100A/14V 100%@80A /13.2V [240V] 35%@200A/18V 60%@160A/16.4V 100%@130A/15.2V Plasma: [120V] 35%@25A/90V 60%@22A/88.8V 100%@20A/88V [240V] 35%@50A/100V 60%@40A/96V 100%@ 30A/92V Stick: [120V] 35%@100A/24V 60%@80A/23.2V 100%@60A/22.4V [240V] 35%@160A/26.4V 60%@130A/25.2V 100%@100A/24V
OUTPUT RANGE : AMPS/VOLTS	TIG: [120V] 5-125A/10.2-15V [240V] 5-200A/10.2-18V Stick: [120V] 5-100A/20.2-24V [240V] 5-160A/20.2-26.4V Plasma: [120V] 20-25A/88-90V [240V] 20-50A/88-100V
OPEN CIRCUIT VOLTAGE	TIG: 70 V STICK: 70V PLASMA: 250 V
TIG TORCH	26 SERIES (standard type)
PLASMA TORCH	AG60 High Frequency Torch
CONSTANT CURRENT (CC) OUTPUT TYPE	DC (\pm)
STICK CELLULOSE ELECTRODE CAPABILITY 6010,6011	6011 is permissible (DC+). No 6010 capability. The unit works well and is designed for use most other types of electrodes.
INCLUDES	WORK CLAMP WITH CABLE (8 FT), STICK TORCH WITH CABLE (8FT), TIG TORCH: 12 FT, PLASMA AG60 12 FT, CONSUMABLE STARTER KIT FOR TIG AND PLASMA (NO TUNGSTEN)
DINSE CONNECTOR TYPE	25 Series for both positive and negative connectors
POST FLOW	ADJUSTABLE 0-30 Seconds
PROTECTION CLASS	IP21S
INSULATION GRADE	F

General overview: The new digitally controlled SuperUltra 206i from Everlast is an entry level DC TIG, stick and plasma multi-purpose unit, designed for occasional portable repair work and small project use. It is recommended for the welding enthusiast or hobbyist with occasional repair needs and/or light duty welding requirements. The SuperUltra 206i features a lightweight MOFSET inverter design and can provide capable service if used within its intended limits. The SuperUltra 206i is not intended for use in production or for intensive fabrication duties. **NOTE: This unit is not suitable for welding aluminum.**

General Use and Care: Care should be taken to keep the unit out of direct contact with water spray. The unit is rated IP21S, which rates it for light contact with dripping water but should never be used in the presence of water for safety. It is a good idea to remove the welder from the vicinity of any water or moisture source to reduce the possibility of electrocution or shock. Never operate in standing water.

Every 1-2 months, depending upon use, the welder should be unplugged, opened up and carefully cleaned with compressed air. Regular maintenance will extend the life of the unit.

IMPORTANT: Before opening the unit's case for any reason, make sure the unit has been unplugged for at least 10 minutes to allow time for the capacitors to fully discharge. Severe shock and/or death could occur.

Do not restrict air flow or movement of air around the welder. Allow a buffer distance of 2 ft from all sides if possible, with a minimum distance of at least 18" clearance. Do not operate the welder immediately in the weld area or the force of the fan will cause welding issues such as unstable arc, or porosity.

Do not mount in areas that are prone to severe shock or vibration. Lift and carry the welder by the handle.

Do not direct metallic dust or any dirt intentionally toward the machine, particularly in grinding and welding operations. Make sure the panel is protected from damage during welding and cutting operations.



Duty Cycle. This unit can be described as a non-commercial, do-it-yourself type of multi-process unit and is intended for light amateur and hobby use only. Care should be taken not to exceed the duty cycle limit of the SuperUltra 206i for maximum service life. Once the duty cycle has been exceeded, heat may continue to build in

the electronics. The duty cycle is based off a 10 minute duty cycle rating at 40° C. This means that the unit is capable of being operated at the maximum amps for the stated percent of time out of 10 minutes without a cool down break. For the balance of the 10 minute time period, the welder should rest without welding or cutting for maximum service life. The temperature light will come on and the welder will automatically stop welding or cutting when an overheat condition has occurred. If this occurs, stop and allow the unit to cool while switched on. Heat will continue to be generated by and transferred to the electronics after welding has ceased. Welding in humid, or hot conditions can affect duty cycle as well. Do not turn off the overheated welder until it has safely cooled for at least 15 minutes. Once the overheated condition has had time to clear, cycle the power switch off and back on to reset the unit. Do not operate the welder with the covers removed. The duty cycles are rated at maximum amps and are as follows:
120V:TIG @ 35%, Stick@ 35%, Plasma@ 35%
240V:TIG@35%, Stick@35%, Plasma@35%

Over Current. Over currents can occur if there is a fault in the power supply system or inside the unit. If this occurs, and the LED lights up, turn the unit off, check for external causes and remedy the problem. If none is found, cycle the power switch off and then back on. If the over current light does not clear after cycling the power switch, contact Everlast for trouble shooting.

HF Start. The welder uses High Frequency to start the TIG arc and plasma cutter arc. HF is generated by a point gap system similar to an older automotive point/coil system. A slight buzz, or hiss may be heard immediately upon start as the HF energizes. A bright blue light may be emitted from the front or side panel as the spark energizes. This is normal and safe as long as the covers are in place. Do not activate the HF unless you are in position and ready to weld to minimize point gap wear. Point gap should measure between .030"-.045". Contact Everlast for adjustment instructions if HF appears to malfunction while either in Plasma or TIG mode.

This manual has been compiled to give an overview of operation and is designed to offer information centered around safe, practical use of the welder. Welding is inherently dangerous. Only the operator of this welder, can ensure that safe operating practices are followed, through the exercise of common sense practices and training. Do not operate this machine until you have fully read the manual, including the safety section.

QUICK SETUP GUIDE: TIG CONNECTIONS

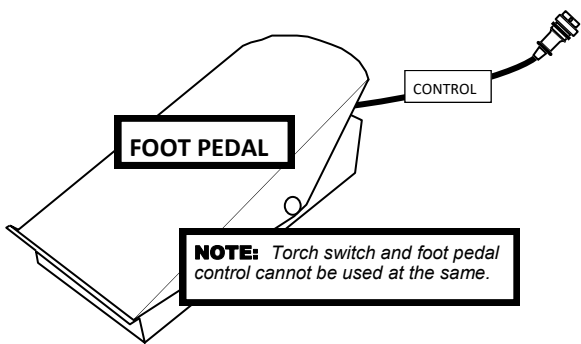
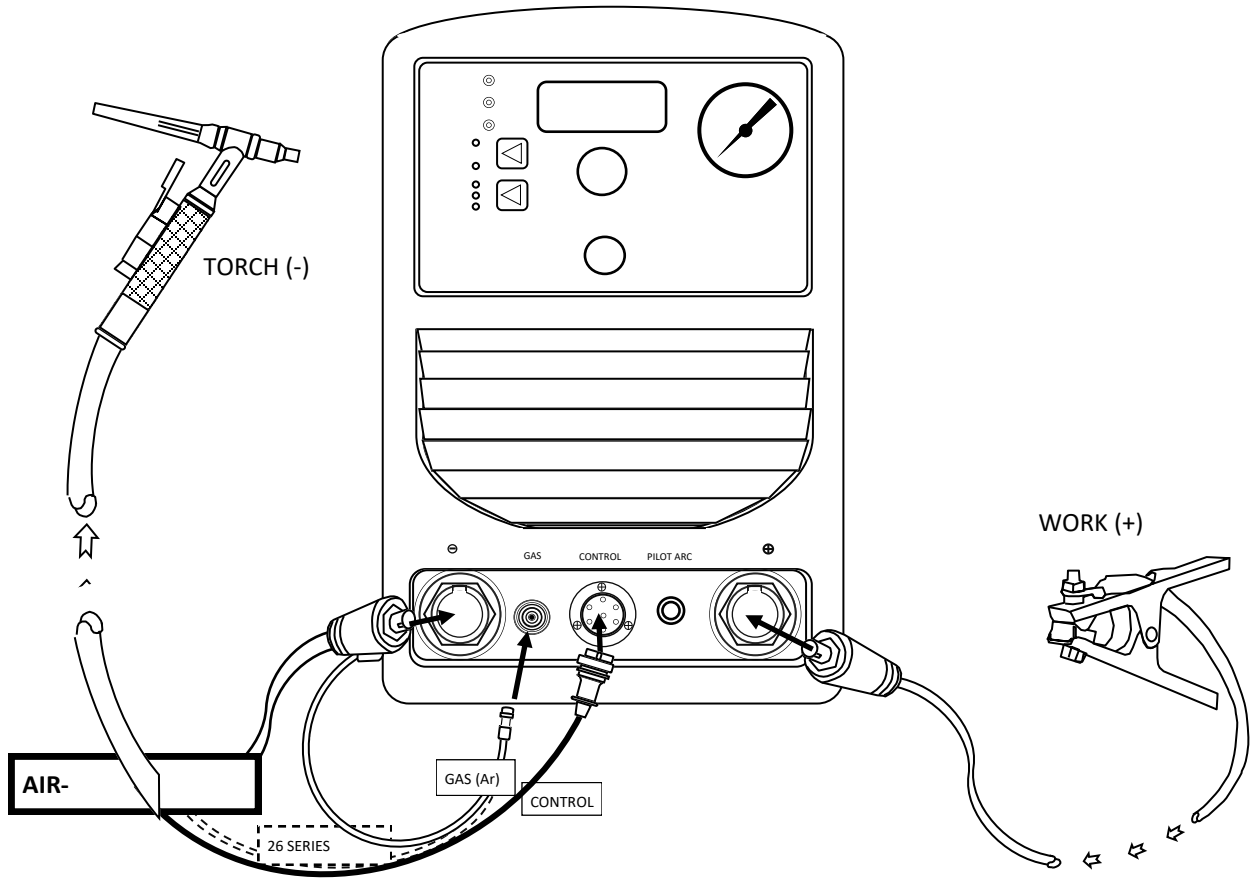

QUICK SETUP GUIDE: PLASMA CONNECTIONS

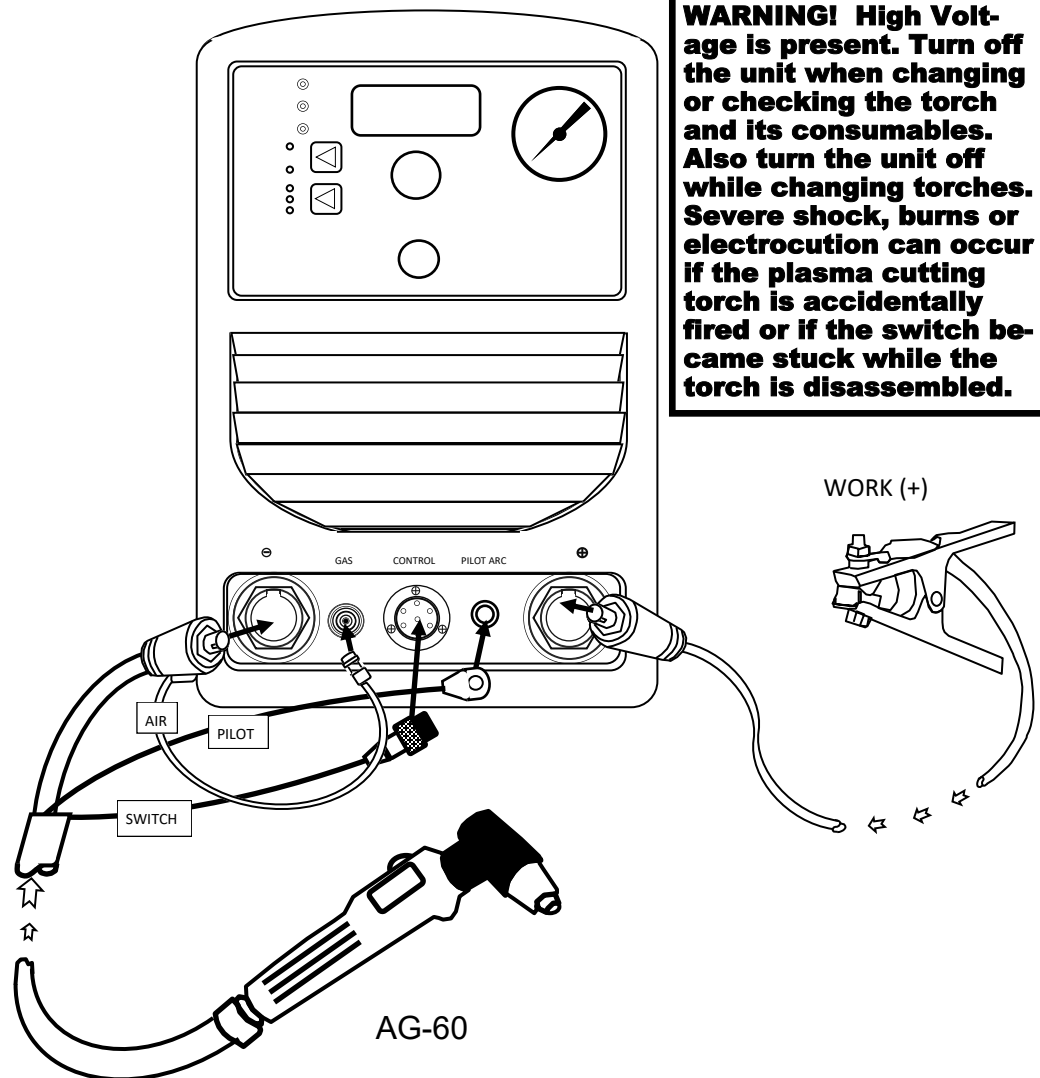

NOTES:

- 1) Do not attempt to use the foot pedal to control the amps in Plasma mode.
- 2) Do not flip the process switch while cutting or unit failure may result.
- 3) Attempt to cut only when air pressure is present. Always check gauge to confirm air pressure is present before cut.
- 4) Do not exceed 85 psi air supply pressure from the compressor or failure of components may result.
- 5) Adjust torch operation pressure to 55-65 psi for best results while post flow is flowing. (Increase post flow time to maximum to allow enough time to set pressure.)
- 6) When using the unit below 40 amps, the nozzles will need to be changed out for ones with a smaller diameter orifice. Everlast is the OEM supplier of the torch but not the manufacturer. Low amp cuts may be unstable unless the size is matched to the amps being used. Although the unit can be adjusted as low as 20 amps, this does not guarantee stable cutting at this amperage. Minimum suggested cutting amps is 25-30 amps for the AG 60 torch with the smallest available consumable. Other torches with smaller consumables may be fitted to supply better low end cutting capability.
- 7) Do not use the pilot arc continuously. It is designed for momentary use. Do not fire the torch unless you are ready to cut or you are adjusting the cutting pressure. Excessive use accelerates consumable wear, point gap wear, and can also damage surrounding electronics. **ALWAYS CUT WITH THE WORK CLAMP ATTACHED.**
- 8) If the pilot arc does not transfer and only a shallow cut or gouge is noticed, check the work clamp to make sure it is attached directly to clean rust free area of the work piece and that the cable is secure to both the torch and work clamp. Make sure that the cables are located securely in the connectors.

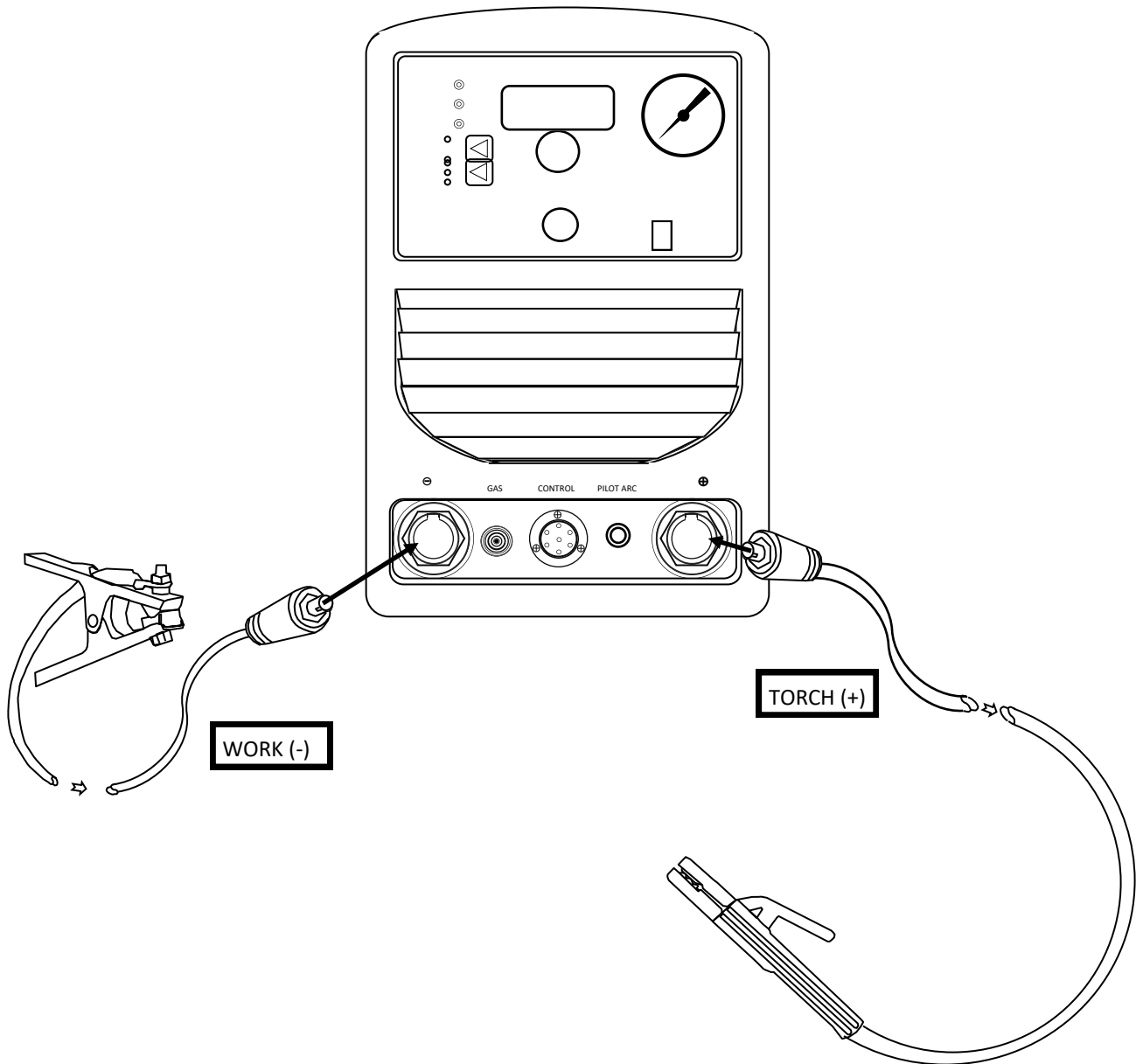
QUICK SETUP GUIDE: STICK POLARITY AND CONNECTIONS

NOTE: When changing from Stick to Plasma cutting or TIG, don't forget to change polarity of the torch and the work clamp. If polarity is not correct, welding and cutting problems will result. Also, change the Plasma Torch, TIG torch and stick connections with the machine turned off for safety and to prevent accidental firing of the torches.

**QUICK SETUP GUIDE: REAR CONNECTIONS FOR PLASMA OPERATION
Compressor and Dryer Diagram**

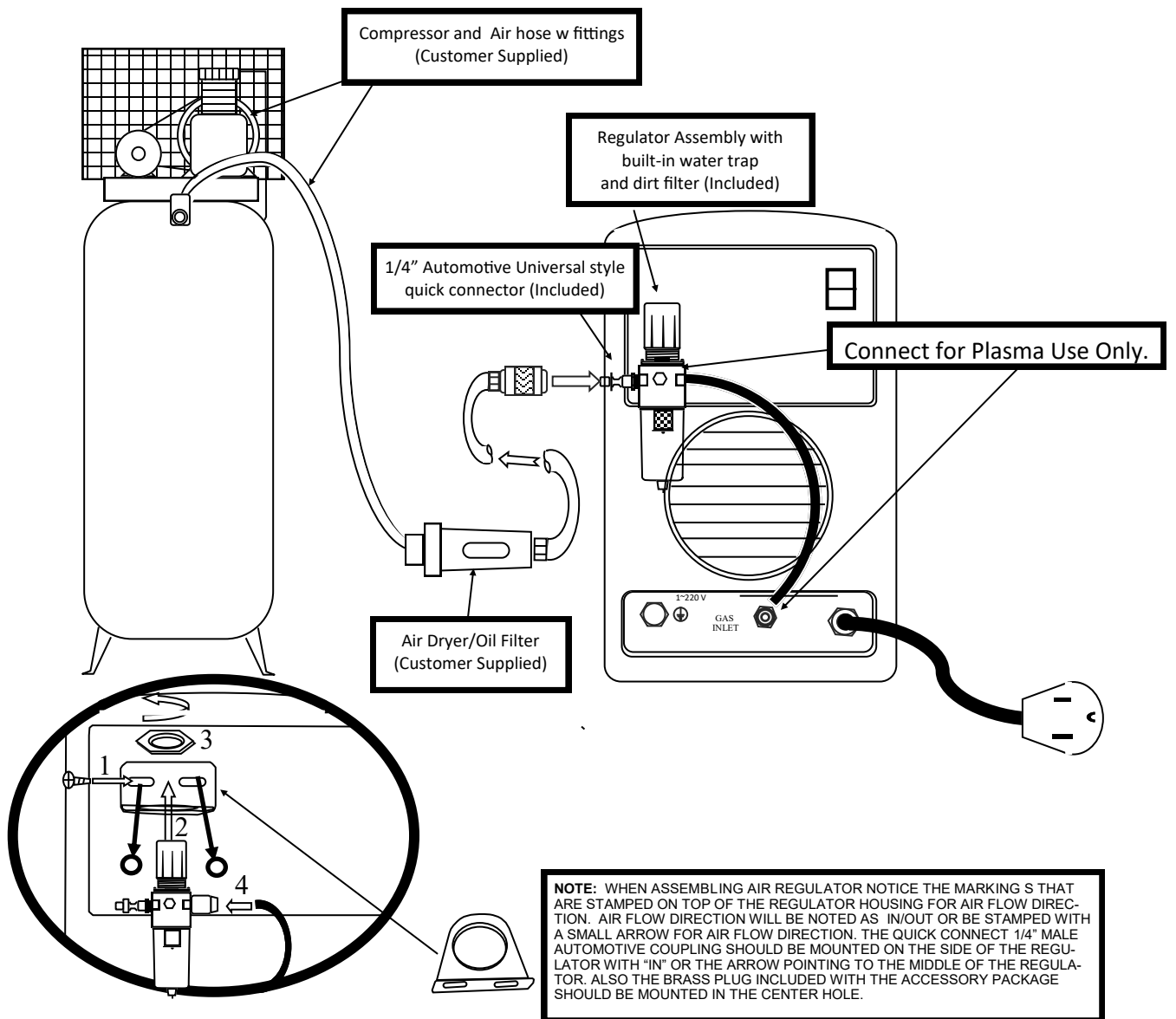

NOTE: A SEPARATE AIR DRYER BETWEEN THE AIR COMPRESSOR AND REGULATOR ASSEMBLY MUST BE INSTALLED AS CLOSE TO THE UNIT AS PRACTICAL. THIS IS A CUSTOMER SUPPLIED ITEM. THIS WILL REDUCE CUTTING ISSUES SUCH AS SPITTING, POPPING AND RAPID CONSUMABLE WEAR. THE REGULATOR/FILTER THAT IS INCLUDED IS NOT SUFFICIENT TO REMOVE ALL MOISTURE. IT SERVES ONLY AS A WATER TRAP AND FINE SEDIMENT FILTER. ANY AIR COMPRESSOR SYSTEM PRODUCES MOISTURE IN ALMOST ANY ENVIRONMENT REGARDLESS OF HUMIDITY LEVELS IN THE ATMOSPHERE. DAILY DRAINING OF THE AIR COMPRESSOR IS RECOMMENDED AS WELL FOR BEST RESULTS. THE AIR SUPPLIED TO THE PLASMA CUTTER SHOULD BE OF SIMILAR QUALITY USED FOR AUTOMOTIVE PAINTING. DIFFERENT STYLES OF DRYERS ARE AVAILABLE. THE MOST INEXPENSIVE AND COMMONLY AVAILABLE IS THE REPLACEABLE DESSICANT TYPE USED FOR AUTOMOTIVE PAINTING. DAMAGE DONE TO THE TORCH AND THE PLASMA CUTTER (INCLUDING BUT NOT LIMITED TO: SHORTING, CORROSION AND DETERIORATION OF INTERNAL LINES AND COMPONENTS) AS A RESULT OF EXCESS MOISTURE IS NOT COVERED UNDER WARRANTY. ADDITIONALLY, A FILTER SHOULD BE INSTALLED IN-LINE NEAR THE COMPRESSOR. THAT WILL FILTER ANY EXCESS OIL OR OIL BLOW-BY FROM THE LINE IF NECESSARY. DO NOT USE WITH AN OILING SYSTEM DESIGNED TO AUTOMATICALLY LUBRICATE AIR TOOLS. IT IS ADVISABLE TO USE THE PLASMA CUTTER WITH A NEW AIR HOSE/LINE THAT IS FRESH WITHOUT MOISTURE OR LUBE CONTAMINATION. IF THE AIR PRESSURE DROPS FROM THE COMPRESSOR TO THE CUTTER MORE THAN 5-10 PSI, OR AIR FLOW IS INSUFFICIENT, INCREASE TO A LARGER SIZE DRYER/FILTER OR AIR HOSE. FAILURE TO USE THE PROPER DRYER/FILTER IS THE NUMBER ONE CAUSE OF CUTTING ISSUES.

QUICK SETUP GUIDE: REAR CONNECTIONS FOR TIG / WIRING (US/Canada)

SUPPLIED PLUG IS A NEMA 6-50P, THE STANDARD PLUG FOR MOST 1 PHASE 240 V WELDERS IN THE US AND CANADA. DO NOT MODIFY.

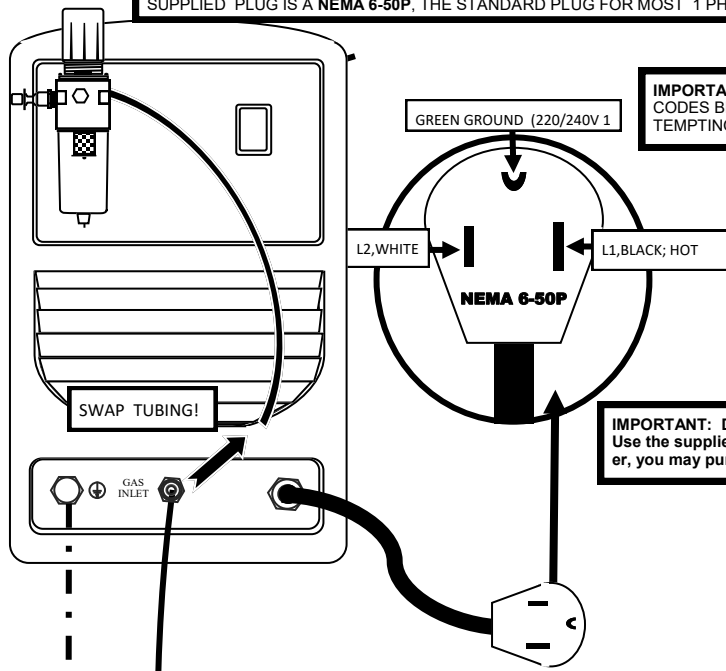

IMPORTANT: ALWAYS CONSULT A LICENSED ELECTRICIAN AND LOCAL CODES BEFORE WIRING YOUR WELDER AND OR PANEL OR BEFORE ATTEMPTING TO MAKE ANY NEW ELECTRICAL CONNECTION.

IMPORTANT: Do not remove the installed 240V plug to use your welder on 120V. Use the supplied adapter. If you do not have an adapter, or have lost your adapter, you may purchase a 240V to 120V standard adapter from Everlast.

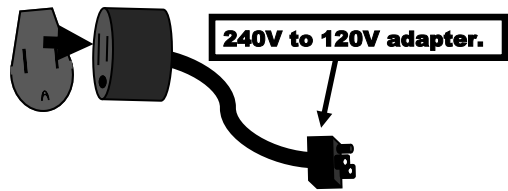

Some countries/regions use Liters per minute (LPM), and others use Standard Cubic Feet per Hour (SCFM) as the standard unit of measurement. Please note which unit your flow meter uses before attempting establish your flow rate. The marking for the flow meter is located on the clear plastic housing. 1 unit of LPM is roughly equal to 2 units of CFH.

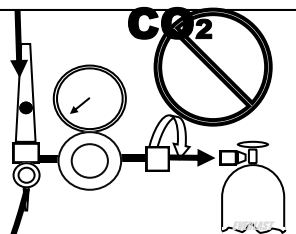

NOTE: Use Ar or Ar/He only. Do not use more than 25% He in the Ar/He gas mix.

NOTE : The SuperUltra 206i uses the same connection/input point for the TIG shielding gas and for the Plasma air input. This requires swapping the TIG and Air input hoses at the lower connection point when changing processes. Do not run the argon supply line through the air regulator. A manifold system may be made from a T configuration consisting of two ball valves or a Y valve (both customer supplied) to switch between the compressed air input and Argon shielding gas as needed without disconnecting and reconnecting the gas/air lines every time the process is changed. If no switching valve or manifold system is used, then you must manually change the input supply every time you change processes. Do not run Argon through the air regulator/filter.

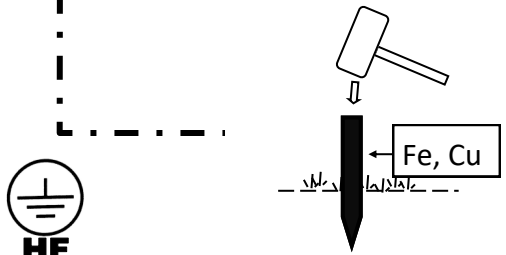

NOTE: TO PREVENT STRAY HIGH FREQUENCY INTERFERENCE, THIS UNIT PROVIDES AN ADDITIONAL GROUNDING POINT AT THE REAR OF THE UNIT. IT SHOULD BE DIRECTLY GROUND THROUGH A SEPARATE WIRE TO AN OUTSIDE METAL ROD DRIVEN IN THE GROUND. THIS HELPS PREVENT BLEEDBACK OF HF INTO THE POWER GRID, AND HELPS MUTE HF INTERFERENCE. ADDITIONALLY, ALL SURROUNDING METAL OBJECTS SHOULD BE GROUND INCLUDING THE TABLE, PIPES, WALLS ETC. TO PREVENT ELECTRICAL INTERFERENCE WITH OTHER CIRCUITS. DO NOT COUPLE THIS WIRE TO THE GROUND PROVIDED IN THE ELECTRICAL CIRCUIT.

FRONT PANEL FEATURES AND CONTROLS

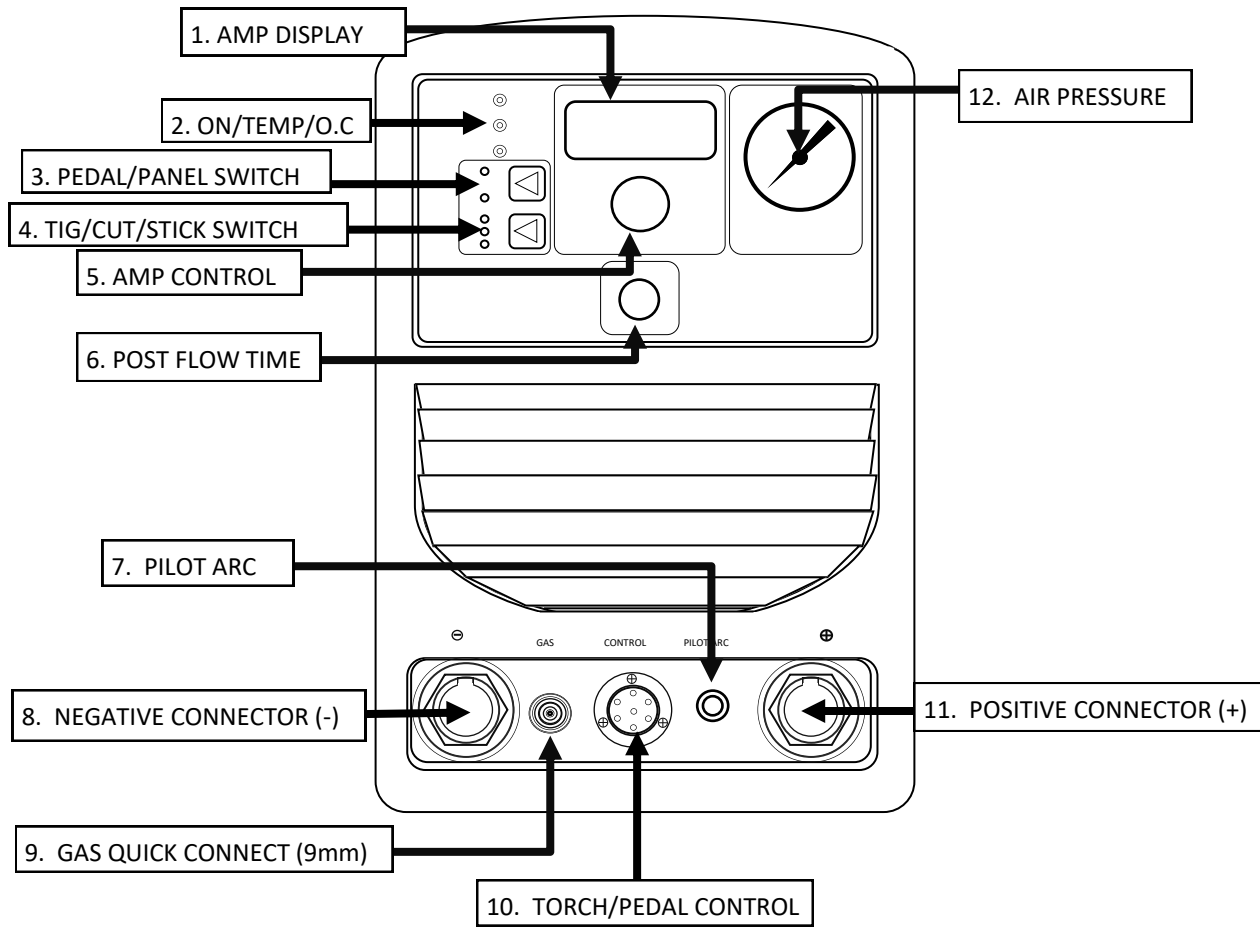

FRONT PANEL FEATURES AND CONTROLS CONTINUED

SUPERULTRA 206i FEATURES	PARAMETERS	PURPOSE
1. Amp Display	N/A	Indicates actual amp output while welding. While adjusting or while not welding, the function of the display changes to display the selected amperage.
2. On/Temp/ Duty Cycle	On/Off	The On indicator should always be lit while the unit is plugged in and the power switch is switched on. If the Overcurrent light is lit, turn the unit off and check for possible causes including undersized cables, poor connections and overheating cables. If the Duty cycle is lit, do not turn off the unit until it has had sufficient time to cool (10-15 minutes). Cycle the power switch to reset the machine only after the machine has had time to cool. The duty cycle and overcurrent warning lights should go off after cycling the power switch on the machine. If it does not, contact Everlast.
3. Panel/Pedal Switch	N/A	This switch determines which mode controls the unit, the torch switch (Panel) or the pedal. Using either one will determine how the unit reads and sets the maximum output of the machine.
4. TIG/CUT/STICK	N/A	This switch selects processes. Do not switch this switch while welding or cutting, Do not switch it with the wrong torch connected or immediate failure of the unit may result. Improper polarity can contribute to torch failure as well. Make sure all connections are installed properly before cutting or welding.
5. Amp Control	N/A	Controls amperage while welding or cutting by using the knob to preset maximum amperage.
6. Post Flow Control	0-30 Seconds	Sets the post flow time of the shielding gas while welding in TIG mode. While in plasma (cut) mode, it sets the post flow time of the air. Time is an approximation only and can vary a little from the setting posted on the dial. The air or shielding gas may stop flowing before full maximum time is reached. Consider the maximum setting mark a reference guide only.
7. Pilot Arc	N/A	This connection is only used with the plasma cutting torch. The small ringed wire connects here. Unscrew the plastic thumb nut and attach the wire to the post. Reinstall the thumb nut over the wire with finger pressure only. Do not overtighten
8. Negative Connector	DINSE 25	Location of the negative terminal connection. Dinse-style. For Stick: Work Clamp Connection. For TIG: Torch Connection. For Plasma: Torch Connection.
9. Quick Connect Gas Outlet	9 mm "B" Size	Connects the shielding gas to the TIG torch. To connect: Push the torch fitting into the connector until the collar slides forward with a click. To Release: Slide the collar back and it will automatically release. Do not turn or twist the connector.
10. Control Connector	7 Pin	Connect the foot pedal or torch switch to this socket to control the welder. Only the foot pedal or torch control connector can be plugged in at one time. If the torch has a torch switch feature, tie the loose connector back and leave it disconnected while using the pedal.
11. Positive Connector (Work Piece on some models)	DINSE 25	Location of the positive terminal connection. Dinse-style connector. For Stick: Torch connection. For TIG, Plasma: Work Clamp Connection.
12. Air Pressure Gauge.	85 psi max supply 55-65 psi operating	Use the air pressure to measure air supply pressure for the plasma cutting process only. The pressure is irrelevant while being used for TIG welding, although some pressure may register while the gas is actively flowing. Supply air pressure should not exceed 85 psi from the air compressor or internal leaks may develop. Adjust the operating pressure while air is flowing. Adjust the air pressure to 55-65 psi and increase or decrease pressure from there to achieve optimum cutting results while air is actively flowing. To adjust air pressure with torch, briefly fire torch with post flow set to maximum. Adjust air flow while the air is still flowing. Use air only for cutting. If a large differential in air pressure is observed (more than 10-12 psi), check for restrictions, kinks or blown connections. If all checks out ok, you may need to use a larger diameter supply hose or compressor.

REAR PANEL FEATURES AND CONTROLS

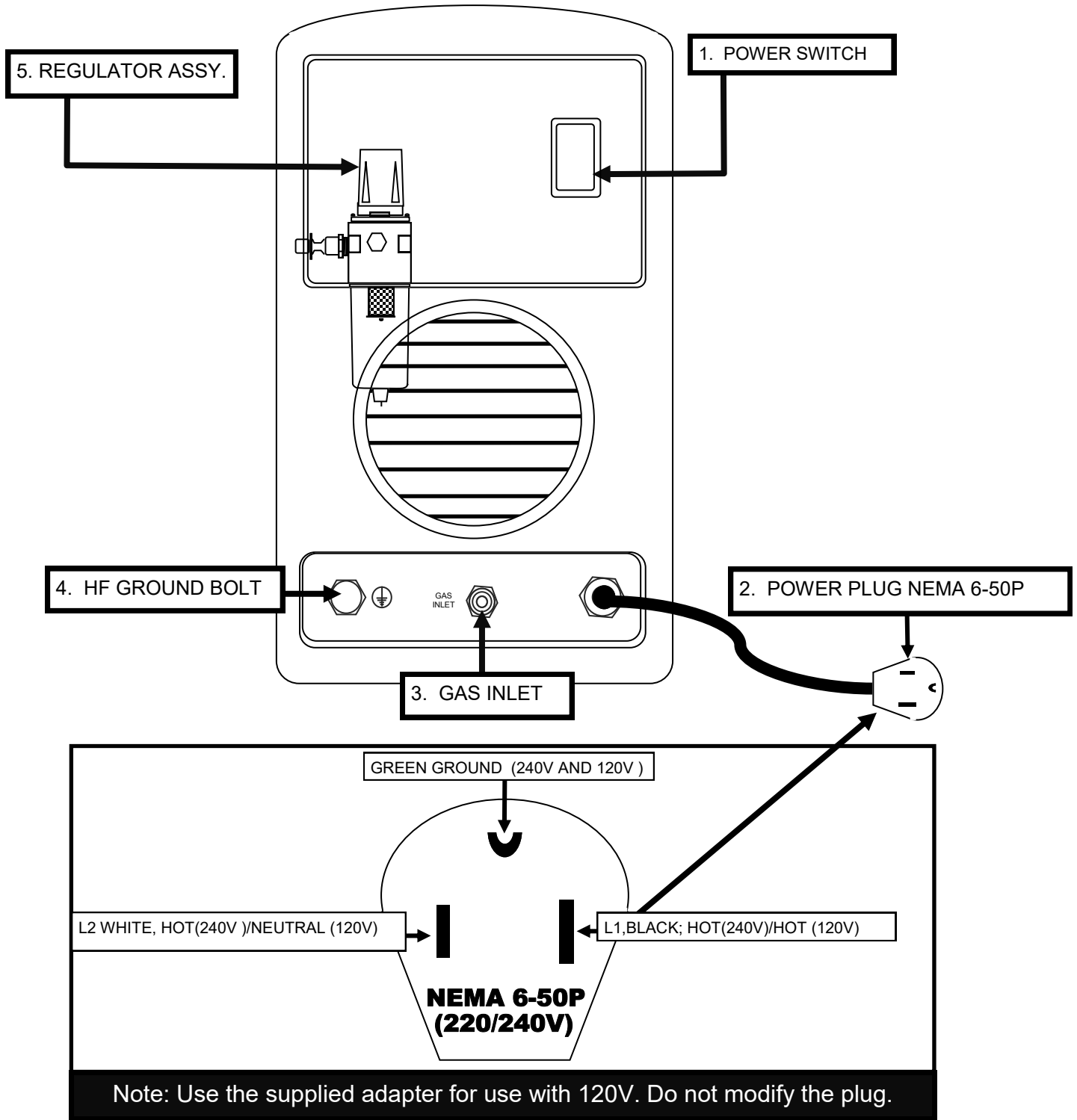

For 240V welder circuits, note that 3-wire, 240V welder circuits use different standard colors than for 4 wire 240V.

REAR PANEL FEATURES AND CONTROLS CONTINUED

SUPERULTRA 206i FEATURES	PARAMETERS	PURPOSE
1. Power switch	On/Off	The rocker switch serves as the On/Off switch for the welder. Always turn the welder on and off by the power switch first before using any main disconnect switch.
2. Power Cord and Plug	120/240 V 1 phase, 50/60 Hz NEMA 6-50P.	The SuperUltra 206i is fitted with a standard NEMA 6-50 plug. This is the industry-wide standard plug for welders in the US and Canada. Other countries vary plug configuration as well as input. When 120V use is desired connect the pigtail, 240V to 120V adapter to reduce the input. No rewiring is required as long as 120V input power supply conforms to the local and national codes, which includes using proper wire gauge and breaker sizing. Always consult a licensed electrician. Do not rewire the unit. When using on 120V, make sure the breaker and wiring is sized properly for use or damage to the machine and/or wiring can result. NOTE: Operating on maximum output on 120V is not recommended for long periods of time on standard household wiring (usually wired as 15 to 20 amps only). A 120V, use 30 amp breaker or fuse (designated as slow trip breaker or slow blow fuse) along with heavier than standard gauge wiring, will be required to operate for sustained periods of time on 120V while welding or using at maximum output. Consult a licensed electrician before operating on 120V to confirm wiring and breaker suitability for this type application.
3. Gas Input Connection	5/8" CGA	This is connection point for the TIG shielding gas and air supply for the plasma cutter. The unit is supplied with a 5/8 CGA fitting to connect directly to the argon regulator and to the unit's air supply filter. This fitting is the standard shielding gas fitting found on most Argon/inert gas regulators in North America. Make sure that all connections are tight and secure. Do not use thread tape or other compounds on the compression fittings. If you suspect leaking, test the connection with a solution of mild soapy water. If bubbles are seen, retighten or reinstall the tubing. While changing processes, the fittings must be swapped. Do not run the Argon gas through the air regulator/filter. As the unit comes equipped, the unit cannot remain connected to both the air supply and the argon supply at the same time. However, a T-fitting or Y-fitting may be placed inline at the connection to leave both argon and air hooked up without having to swap out the lines (customer supplied). Running humid air through the TIG torch (as a result of poor maintenance of the plasma cutting aspect of the unit) will create problems. Be sure to use the air dryer, and other items recommended. Running Argon through the plasma cutting filter and tubing is a prime way to introduce unwanted moisture to the TIG torch.
4. HF Ground Bolt	N/A	HF energy can be devastating to surrounding electronic equipment. If the operating environment includes electronic equipment, this connection can serve as a direct path to an outdoor grounded metal rod that is isolated from the main electrical circuit to help bleed off excess HF circuit. All metal parts inside the building should be grounded as well, including pipes, tables, and even metal siding. HF energy has been known to bleed back into the power grid and disrupt electronic devices further down the grid. If the point gap becomes out of adjustment, more HF energy may build up, or even jump across circuitry within the welder. It is recommended that a small, separate ground wire (minimum 14 gauge) be attached at this point while in use.
5. Air Filter and Regulator Assembly	85 psi maximum Supply pressure. 55-65psi operating pressure while cutting	The air filter/regulator filters fine particulates and large drops of water. The filter is not designed to have argon flowing through it. A separate air dryer must be installed inline to prevent rapid torch and consumable wear (Customer supplied). The filter assembly is not designed to remove all moisture from the air. Everlast does not warranty damage caused to torches or consumables by moisture. Residual moisture in the line also can contaminate the system, causing problems while TIG welding. The number one issue experienced with Plasma cutting, (causing a wide variety of symptoms, including rapid wear and unstable arc) is the presence of moisture in the air line. To adjust the pressure, for cutting, simply pull the knob up until it clicks and rotate it clockwise to increase the pressure, and rotate it counter clockwise to decrease the pressure. To adjust the air pressure correctly, adjust it while the air is flowing during post flow mode. If a flow tube for the torch is provided, adjust it so the ball floats in the window as depicted in the torch manual. Turn the Post flow to maximum, fire the torch, then make adjustments to the air pressure while it is flowing. Adjust pressure to 55-65 psi.

NOTE: Never operate this unit on a generator that is not certified by its manufacturer to be "clean" power, which is typically less than 5% Total Harmonic Distortion (THD). Operating the unit on square wave output or modified sine wave generator is strictly prohibited. Contact the manufacturer of the generator for this information. Everlast does not have an "approved" list of generators. But, if the generator is not listed as clean power by its manufacturer, then operation is prohibited. Generators that do not at least meet the operating input requirements of the welder are also not to be used with this unit. Surge amp capability of the generator should equal or exceed the maximum inrush demand of the welder (see specifications) But the surge capability should not be used as the only factor. The regular, running output of the generator should match or exceed the running or "rated" demand of the welder. Any damage done by operating the welder on a generator not specified by its manufacturer to be "clean", will not be covered under warranty. This also includes suspect power sources where voltage is below 208 V and above 250 V.

TUNGSTEN PREPARATION

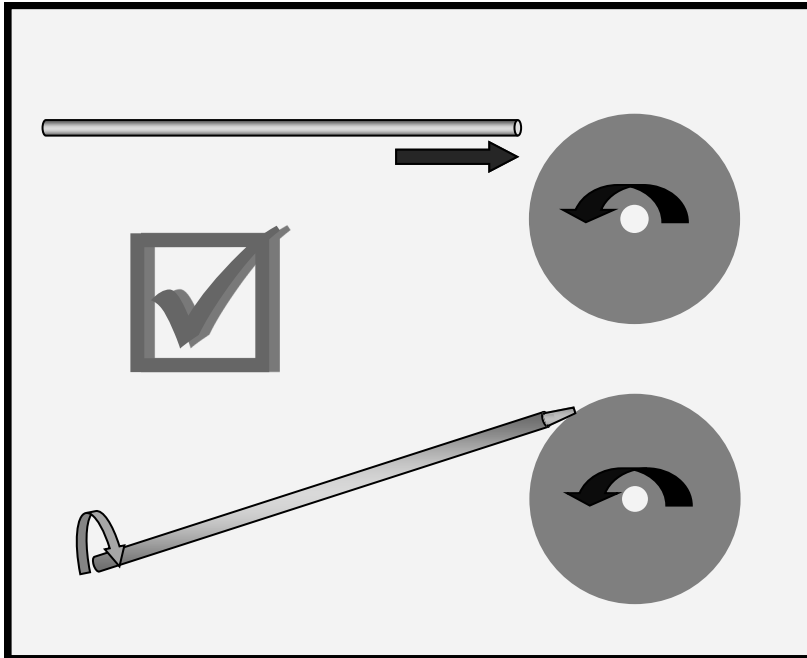

1. Use a dedicated grinding wheel or contamination may result. Do not breath grinding dust! Wear eye protection and gloves.

2. Hold Tungsten firmly.

3. Grind perpendicular to grinding wheel face. Allow tungsten to grind away slowly, creating point.

4. Rotate tungsten quickly as it is being ground to keep point even and symmetrical.

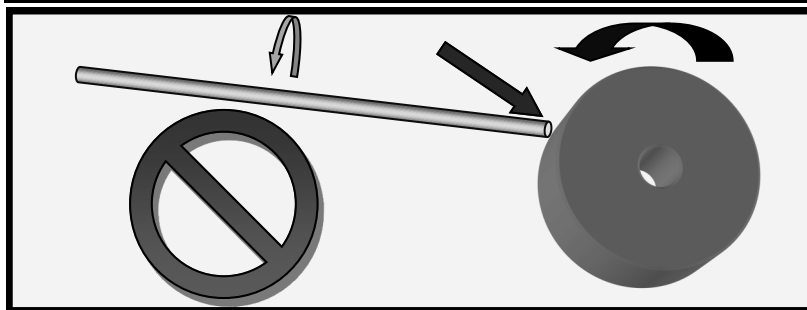

DO NOT GRIND TUNGSTEN PARALLEL TO WHEEL FACE OR AN UNSTABLE ARC WILL RESULT.

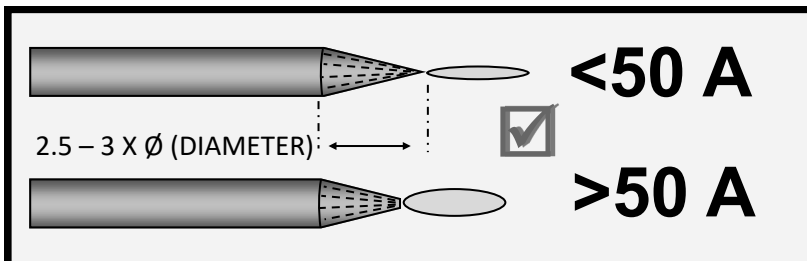

Use a point for low amp use to help control arc. Create a slight truncation on the tip for higher amp use for best arc stability. Grind the tip so that it is 2.5- 3 times longer than the tungsten is wide (Diameter).

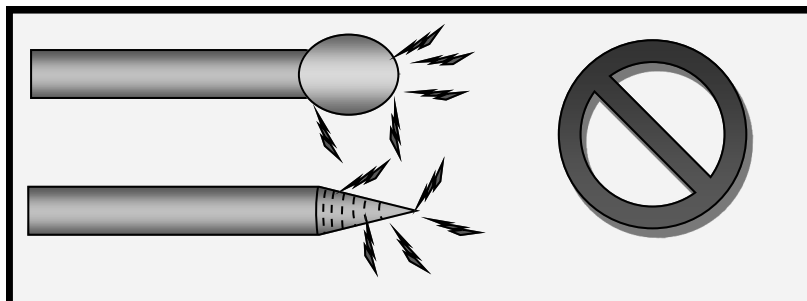

DO NOT BALL TUNGSTEN. An ERRATIC ARC MAY RESULT. MAKE SURE GRINDING MARKS RUN PARALLEL AND IN LINE WITH THE TIP. CONCENTRIC MARKS WILL CAUSE AN ERRATIC ARC.

Be sure to select the best Tungsten for your application. Low amp starts are difficult if too large of Tungsten is used. Use only lanthanated, ceriated or thoriated Tungsten. Do not use pure Tungsten (marked with green tip).

GENERAL POLARITY RECOMMENDATIONS*

*Follow manufacturer of stick electrode for complete polarity recommendations

PROCESS	TORCH POLARITY	WORK POLARITY
TIG (GTAW)	-	+
STICK (SMAW)	+	-

TIG (GTAW) OPERATION GUIDE FOR STEEL (ALUMINUM)*

*As a general rule, set amperage using 1 amp for every .001" of metal thickness for aluminum. Less is required for DC.

METAL THICKNESS	WELDING AMPS (A)	TUNGSTEN DIA.	Ar FLOW RATE
1-3 mm/.040"-1/8"	40-80 (60-125)	.040"-3/32"	8-15 CFH
3-6 mm/ 1/8"-1/4"	80-200 (125-200)	3/32"-1/8"	15-25 CFH
6-10 mm 1/4"-3/8"	150-200 (200-250)	1/8"-1/4"	20+ CFH

STICK (SMAW) OPERATION GUIDE

METAL THICKNESS	ELECTRODE SIZE	WELDING AMPS
< 1 mm/.040"	1/16"	20-40
2 mm/.080"	3/32"	40-50
3 mm/ 1/8"	1/8"	90-110
4-5 mm/ 3/16"	1/8"	90-130
6-10 mm/ 1/4"-3/8"	1/8"-5/32"	130+

TUNGSTEN SELECTION GUIDE FOR AN INVERTER

TYPE	PERCENT	COLOR	PROCESS	RECOMMENDATION
Pure	100% Tungsten	Green	AC	NOT RECOMMENDED! Do not use in an inverter.
Thoriated (slightly radioactive)	2% Thorium	Red	AC/DC	YES. Great for all purpose welding. Most economical.
Ceriated	2% Ceria	Orange	AC/DC	YES. Good for low amp use.
Lanthanated	1.5% Lanthanum	Gold	AC/DC	YES. Best alternative to 2% Thoriated. Tough performer.
Lanthanated	2% Lanthanum	Blue	AC/DC	YES. Slight advantage over 1.5% Lanthanated.
Zirconiated	1% Zirconia	Brown	AC	NOT RECOMMENDED! Do not use in an inverter.

HIGH FREQUENCY START TIG OPERATION

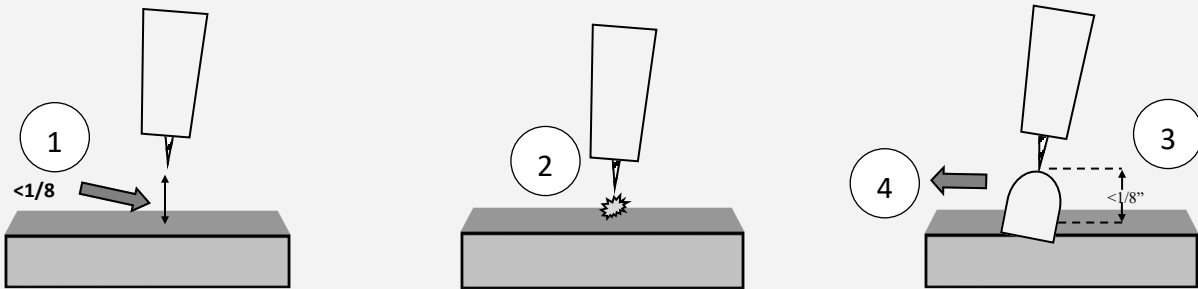

1. Position the point of the sharpened tungsten about 1/8" or less above the metal.
2. Press the torch trigger or press the foot pedal to initiate the arc. The HF arc will be initiated. It may appear briefly as a blue spark.
3. An arc should form almost immediately. If arc does not start, and the HF is creating a spark, then check the work clamp connectivity to the work piece. Grind a clean spot to attach the clamp if necessary. Connect the work clamp directly to the object being welded. Move the tungsten closer to the work. Also check polarity if arc does not start or tungsten balls, or burns quickly. Repeat steps 1 and 2.
4. Leave 1/8" or less gap between the tungsten tip and the metal and proceed with welding, leaving the torch inclined at a maximum 15° angle.

General TIG Arc Starting Steps

1. Turn the unit on, allow time for power up cycle to complete its start up process.
2. Select TIG mode with TIG /CUT/Stick selector button.
3. Plug in the TIG Torch with either the torch switch or foot pedal connected. Then select panel mode or pedal mode with the selector button depending upon whether the foot pedal (pedal mode) or torch switch (panel mode) was chosen for use.
4. Adjust to the desired Post Flow time by rotating the knob to increase/decrease. (Usually .5 to 1 second per 10 amps)
5. Select maximum amps with amp control knob.
6. Start arc as depicted above by either pressing and holding the torch switch or by stepping down slightly on the pedal.
7. If you are using the panel mode, continue to hold the torch switch until you are ready to stop welding. Release the switch. The welding arc will then cease. If you are using the foot pedal raise your foot completely off the pedal and arc will stop automatically.

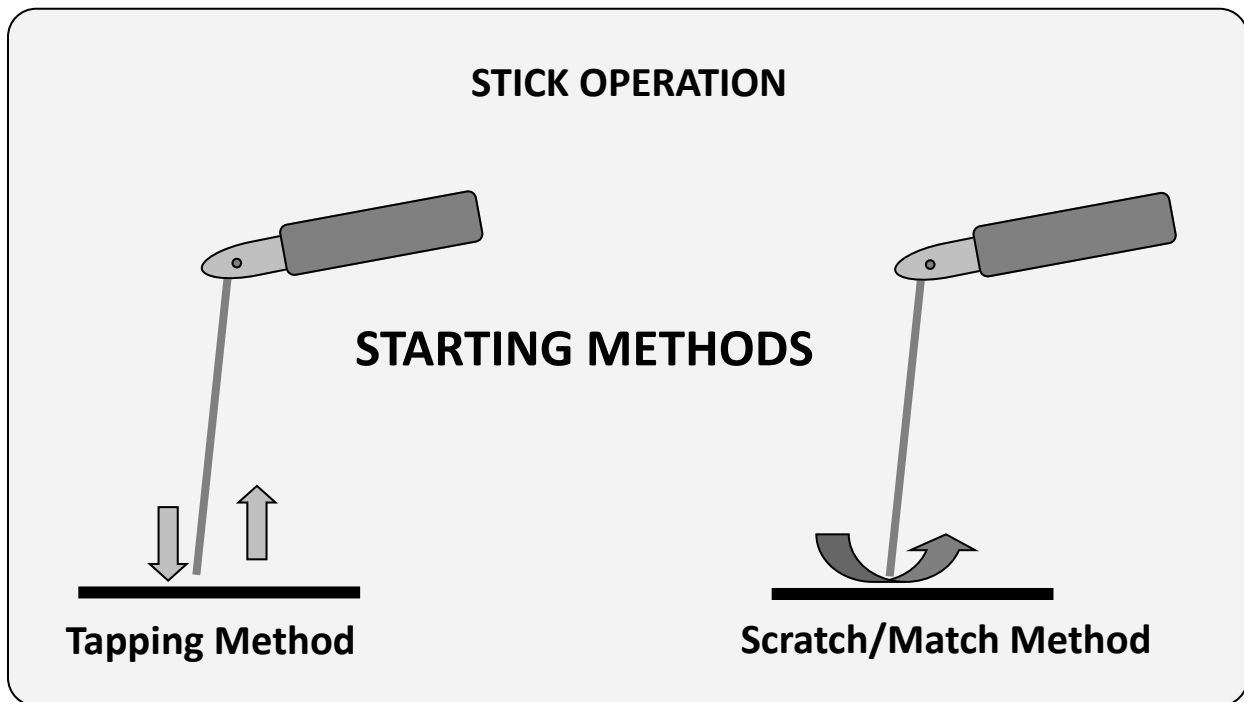

1. Turn on the power switch on the rear of the unit. Allow unit to cycle through its start up program.
2. Select the Stick mode with the TIG/Cut/Stick selector switch.
3. Make sure electrode holder is connected to the positive connector and the work clamp is connected to the negative connector. Remember, this is the opposite connection required for TIG and plasma.
4. Select the desired amperage. Use the electrode diameter selection chart in this manual to determine the approximate range of amps suitable for the rod size selected. Consult the welding electrode manufacturer's recommendation for proper amperage range. Each manufacturer has specific recommendations for its electrodes. Ultimately Amperage is determined by the electrode thickness and the thickness of the metal.
5. Strike the arc with either the tapping method or the match strike method. Beginners usually find that the match strike method yields best results. Professionals tend to gravitate toward the tapping method because of its placement accuracy which helps prevent arc striking outside of the weld zone.

IMPORTANT: Do not weld in the TIG mode with the stick electrode holder still attached.

Helpful Hint: If difficulty is observed in starting the arc, it may be time to readjust the point gap setting found inside. The HF points tend to wear and get dirty over time. This is a normal maintenance item and not something for warranty consideration. Proper point gap adjustment is .035 "to .045". Before attempting to adjust the point gap, be sure to unplug the unit for 15 minutes before removing the rear plastic panel, and the steel case to access the points located near the front of the unit. Do not remove the front panel! Use a feeler gauge to adjust the points to the proper setting. Another possibility is that the air pressure is too low or too high. Worn/loose consumables may cause this as well.

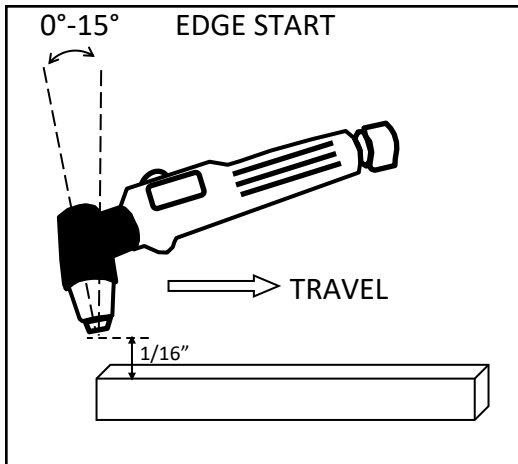

Edge Starts are the best type of start if possible to promote consumable and torch life. This reduces blow back of molten material and allows a smooth gradual start of the cut.

1. Line up the hole on the tip of the electrode on the edge of the cut. Hold torch perpendicular to the cut initially, about 1/16" off the metal.
2. Once the arc starts, wait for the arc to penetrate all the way through the metal.
3. As the torch penetrates its flame all the way through the metal, tilt the torch so there is a slight lead in the flame if metal is thin. If it is thick, keep holding torch in a nearly vertical position.
4. Begin moving the torch in the direction of the cut. Maintain 1/16" standoff height.
5. Move the torch fast enough so the sparks and flame trail from the bottom edge at an angle of no more than 30° and no less than 10° from perpendicular to the metal. Excess angle of sparks/flame indicate too fast of travel speed or practical cut capacity has been reached. Little or no angle indicates too slow of travel speed.

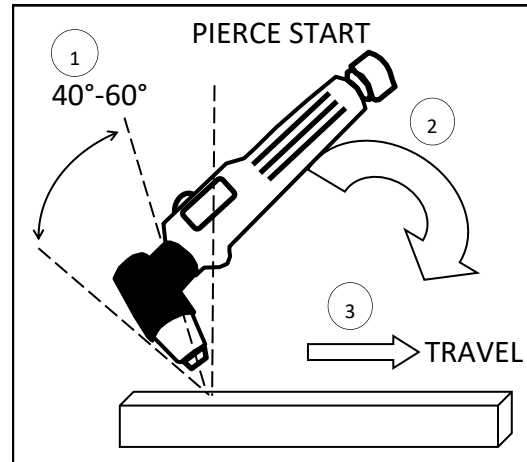

Piercing starts often result in rapid consumable wear and excess blow back of molten metal deposited onto torch and consumables. This should be done only as necessary.

1. Tilt the torch in the direction of travel or toward the side of the metal to be discarded or wasted at a 40° to 60° angle. Slide the yellow safety lock and squeeze the trigger.
2. Once the arc starts, wait for the arc to transfer from pilot arc to the cutting arc.
3. As the torch penetrates its flame all the way through the metal, rotate the torch slowly to the vertical position, as the arc penetrates the metal. Tilt the torch from 0°-15° for thin metal cuts, or hold it nearly perpendicular for thicker metal cuts.
4. Begin moving the torch in the direction of the cut. Maintain 1/16" standoff height.
5. Move the torch fast enough so the sparks and flame trail from the bottom edge at an angle of no more than 30° and no less than 10° from perpendicular to the metal. Excess angle of sparks/flame indicate too fast of travel speed or practical cut capacity has been reached. Little or no angle indicates too slow of travel speed.

IMPORTANT: If you use a standoff guide with the torch, it must be adjusted or bent to provide no more than 1/8" standoff, less if possible. Long standoff heights reduce cut capacity and quality. It also promotes rapid consumable wear and can prevent the pilot arc from transferring.

TIP: For longer consumable life do not use the pilot arc unnecessarily. Rapid wear will occur if the pilot arc stays engaged more than 3 seconds at a time.

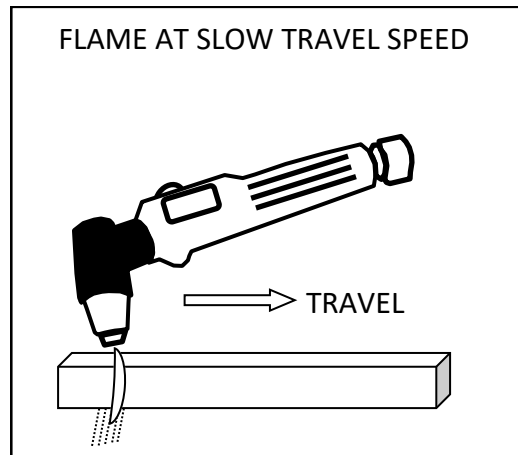
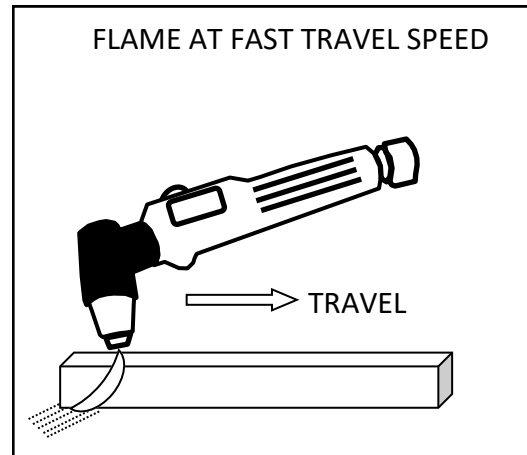
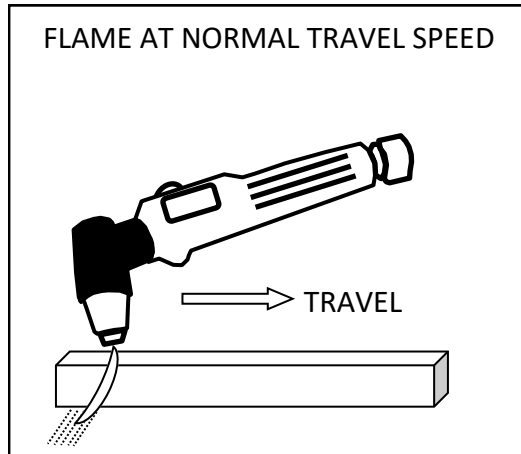

NOTE: When stepping down amps to cut thinner material, or using on 120V, you must change to smaller orifice nozzle for the best cutting results. Too large of an orifice diameter will result in arc instability and a rough cut. Lowering the air pressure below 50 psi to try to get the torch to cut will only result in a lazy, wandering arc or an arc that sputters on and off continuously.

IMPORTANT: Check consumables regularly for wear and change them out before they are completely worn. Allowing the consumables to wear until they quit working may damage related torch components, creating a more costly repair.

AN EXAMPLE OF CUTTING A LEAD-IN WHEN CUTTING OUT A DISK SHAPED OBJECT

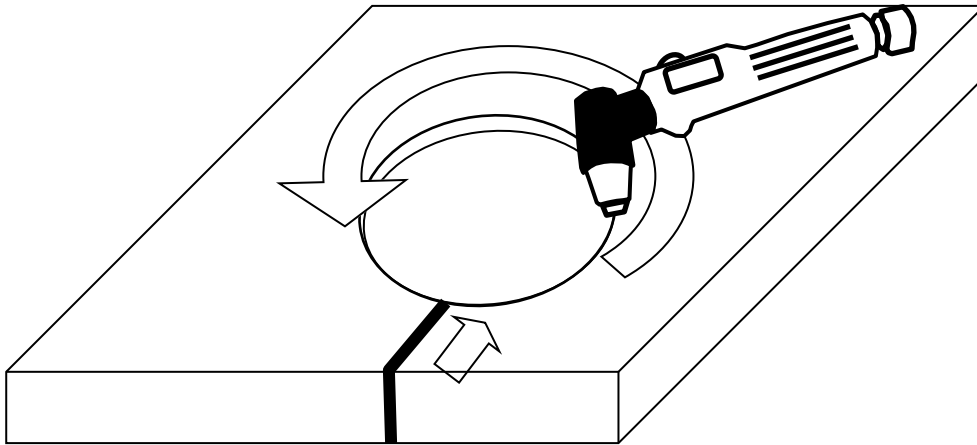

AN EXAMPLE OF CUTTING A LEAD-IN WHEN CUTTING HOLE IN AN OBJECT

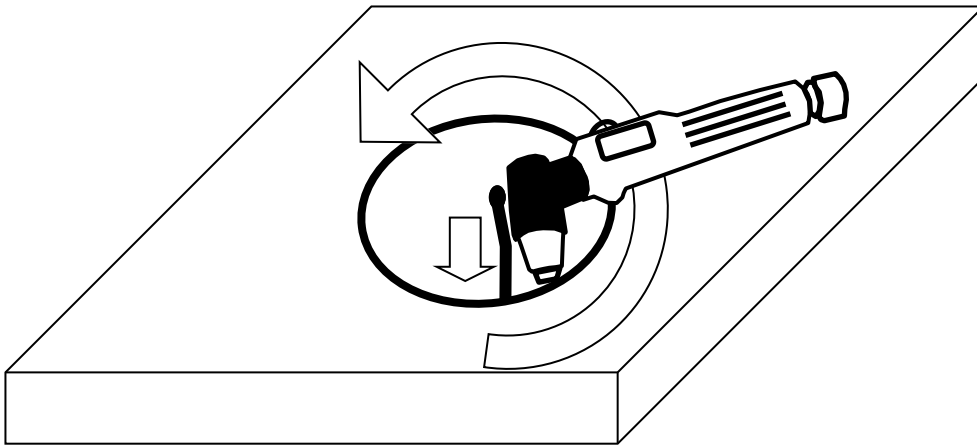

When cutting an object, particularly a pattern shape, where the torch must pierce or re-fire in-line at an intersection of a cut, a lead-in cut should be employed. A lead-in is a cut that is made in the disposable part (also known as a drop) of the object to "lead" into the main part of the cut so that the destructive force of the arc is not directed into the desirable side of the cut itself. Also, all plasma cutters exhibit some angularity or bevel in the cut which is greater on one side than the other. Keep this in mind when cutting an object to size so that too much metal is not accidentally removed.

**RESULTS OF CUT AT CORRECT SPEED,
AIR PRESSURE AND TORCH ANGLE**
SMOOTH, EVEN CUT LINES WITH A S REARWARD SWEEP

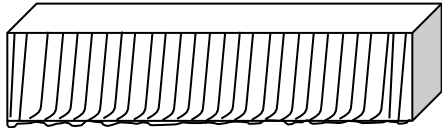

MINIMAL EASY TO CLEAN DROSS

RESULTS OF CUT AT FAST SPEED
ROUGH, DISTINCT CUT LINES SPACED FAR APART

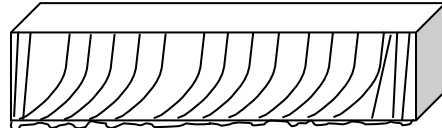

NOTICEABLE SMALL, HARD DROSS

RESULTS OF CUT AT SLOW SPEED
VERTICAL CUT LINES



SIGNIFICANT SOFT, POROUS DROSS

**RESULTS OF TOO MUCH CURRENT OR
TOO MUCH STAND OFF HEIGHT
(SIDE VIEW)**
MELTED TOP EDGE

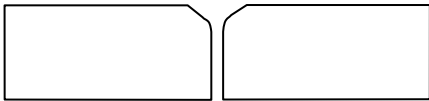

**RESULTS OF WORN CONSUMABLE OR
LOW AIR PRESSURE
(SIDE VIEW)**
SEVERELY ANGLED CUT AT TOP

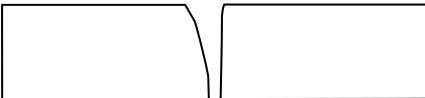

A more detailed note of explanation about the Pilot Arc function: The pilot arc is intended to provide continuous arc when the arc is first started to establish continuity and then shuts off after the arc transfer to the work piece when actual cutting begins. It automatically re-engages when the arc is lost while the trigger is being held. The re-engagement feature is intended for use on expanded metal/grating and for cutting in circumstances where the arc is likely to be lost. It prevents the user from having to manually re-fire the trigger. Do not use this feature excessively or consumable and torch life will be shortened as the consumable itself carries the arc. Do not fire continuously without the intention to cut. This arc is not designed to cut. Always keep work clamp attached directly to the part being cut. If only shallow cutting or light scoring of the metal is noticed, check work clamp connection before continuing cutting operations. This is a symptom of the pilot arc being constantly engaged without arc transfer, and almost always indicates a work clamp or connection problem. It can also indicate a problem with point gap setting. As a generally good practice, only fire the torch briefly when setting the air pressure. Use the post flow timer feature to help adjust the correct pressure while flowing by increasing post flow time to the maximum setting. Do not continue to hold the torch trigger so the air will flow.

EXPANDED VIEW OF TIG TORCH

(Actual appearance may vary slightly from what is listed.)

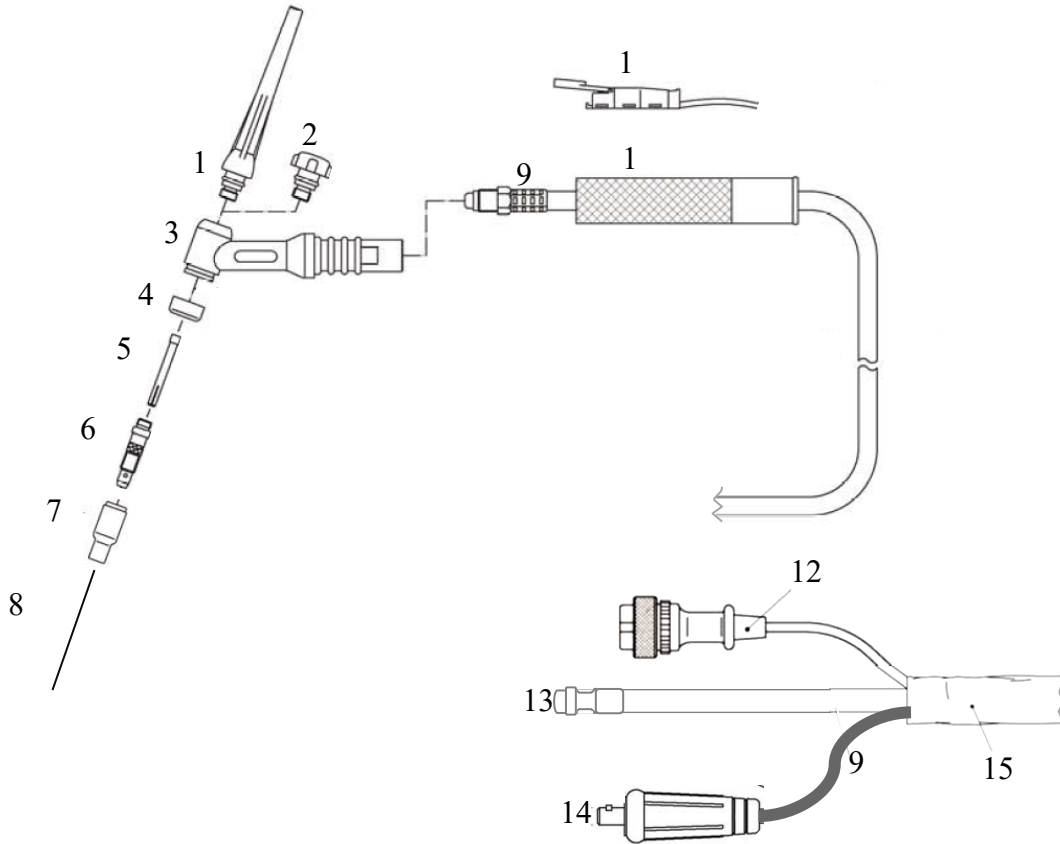

NO.	Parts for Standard 26 Series Torch (18 series uses same consumables and basic design is similar, except water cooler line plumbing)	QTY.
1	Long Back Cap with O-Ring	1
2	Short Back Cap	Opt.
3	Torch Head	1
4	Insulator	1
5	Collet 1/16 or 3/32	1
6	Collet Holder	1
7	Ceramic Cup #5,6, or 7	1
8	Tungsten (customer supplied)	0
9	Torch Cable	1
10	Torch Handle (Blue ergo handle std, not pictured)	1
11	Torch Switch (Built into ergo handle, separate on straight handle)	1
12	Torch Switch Connector	1
13	9mm (1/8") b quick connect coupling (male)	1
14	Power Connector	1
15	Protective Synthetic Rubber Cover	1

AG60/SG 55 PLASMA TORCH

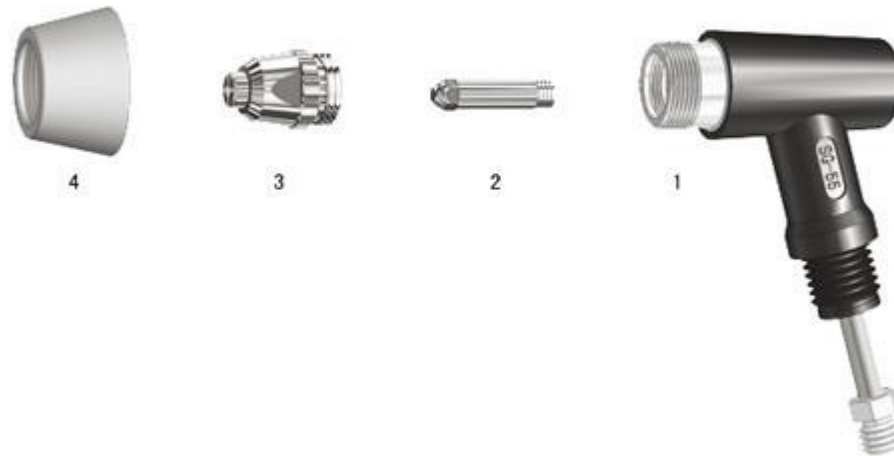

ITEM	DESCRIPTION	PART NUMBER/SKU
1	Torch Head/Body	E-WSD-061
2	Electrode 1.0mm	E-AG60-TIP
3	Tip/Nozzle	E-AG60-EL
4	Shielding Cup	E-AG60-CUP

NOTICE: To cut on thin metal with lower amperages, you should change nozzles to ones a smaller diameter orifice. You should order nozzles/tips with smaller orifices that match your amp output from Everlast and other online sources if lower amp cutting (< 40A) is desired. The stock consumables supplied with the unit are designed to offer the best cut quality with 40-50 amps service at recommended air pressure. (Nozzle orifice dimension is marked on the side in mm.) The standard supplied nozzle/tip diameter may be 1.0 or 1.1 mm. Lowering air pressure with a larger orifice nozzles to attempt to cut thin gauges of metal is not recommended. Lower the amperage and maintain the recommended air pressure settings with nozzles that have smaller nozzles for best cut quality and speed on thin metals. If you are not sure about what size you need, contact Everlast. As a general rule, for each 10 amp unit of drop in amperage below 40 amps, you will want to reduce orifice diameter by .1 mm. Not all orifice diameters and configurations are available from Everlast, but can be bought from other sources.

7 PIN CONNECTOR FOR FOOT PEDAL

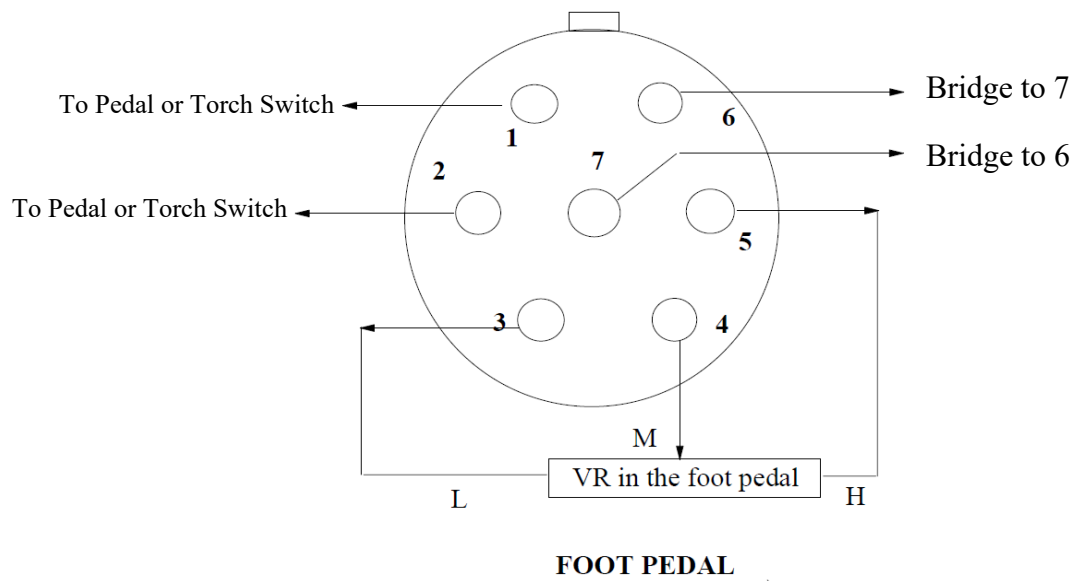

TIG/Stick Trouble shooting:	CAUSE/SOLUTION
Machine will not turn on.	Check cords and wiring in the plug. Check circuit breaker.
Machine runs, but will not weld in either mode.	Check for sound work clamp and cable connections. Make sure work cable and TIG Torch are securely fastened to the Dinse style connector. Reset main power switch if overcurrent light is on. Contact Technical Support.
Arc will not start unless lift started.	Check HF point gap. Set to .035" See addendum or contact Technical Support. Make sure unit is set to HF
Tungsten is rapidly consumed.	Inadequate gas flow. Too small of tungsten. Wrong shielding gas. Use only Ar. Using green tungsten. Use red thoriated or other color. Wrong polarity. Too much AC cleaning.
Tungsten is contaminated, arc changes to a green color.	Tungsten is dipping into weld. Check and adjust stick out to minimum 1/8 inch. Tungsten is melting. Reduce amperage or increase tungsten size.
Porosity of the Weld. Discolored weld color. Tungsten is discolored. Tungsten is consumed, sparking.	Low flow rate of shielding gas. High flow rate of shielding gas. Too short of post flow period. Wrong TIG cup size. Contaminated gas. Weld is in a drafty area. Possible gas leaks internally or externally due to loose fittings. Base metal is contaminated with dirt or grease.
Weld quality is poor. Weld is dirty/oxidized.	Eliminate drafts. Check if there is sufficient shielding gas left in tank. Check gas flow. Adjust for higher flow of gas. Listen for audible click of gas solenoid. If no click is heard, then contact Everlast Support. Clean weld properly, especially in Aluminum. Too short of post flow. Check tungsten stick out.
Over current/Duty cycle LED illuminates. Machine runs, but no output.	Duty cycle exceeded or Over current. Allow machine to cool. Reset main power switch after full cool down period. Make sure fan is not blocked. Check wiring.
Unstable Arc.	Poorly ground or shaped tungsten. Regrind to proper point. Too much AC positive polarity. Reduce balance to 30% or less. Increase AC Frequency.
Other issues.	Contact Everlast support.

PLASMA TROUBLE SHOOTING:	CAUSE/SOLUTION
Air Flows but arc does not start.	Check consumables for wear and tightness. Check fuse. Check Air Pressure. Check point gap. Release trigger and try again. Postflow turned on too long or air pressure is too high.
Air Flows but arc does not start or spark when nozzle is rubbed on the metal.	Fuse blown. Missing swirl ring. Worn or loose consumables. IGBT issue. PCB issue.
OK to cut light is not on. Will not start arc.	Increase air Pressure. Make sure air is connected.
Pilot arc will not light.	Point Gap adjustment incorrect or dirty. Adjust to .030-.045"
Pilot arc will not transfer and amps read approximately 25-27 amps while switch is held. (Arc barely cuts or only "scratches" the surface of the metal or cut is extremely slow on thin materials.)	Check work clamp connection. Make sure rust is removed from work clamp contact area. Faulty Clamp. Arc continuity is not being sensed. If these steps do not correct the issue, contact Everlast.
Arc Sputters.	Inadequate air flow or air pressure. Improperly sized nozzle. Decrease size as amps are lowered. Increase air pressure to 55-75 psi while air is flowing through torch. Loose consumables. Check tightness.
Consumables are dirty, smutty looking upon inspection. Premature wear on consumables. Shortened consumable life.	Moisture, oil contamination of consumable. Wrong consumables. Poor quality aftermarket consumables.
Premature wear on consumables. Short consumable life. Uneven wear of consumables, melting of cup.	Moisture, oil contamination of consumable. Excessive pilot arc time. Improper cutting technique. Wrong piercing technique.
Arc will not start. Air will not flow. Machine runs.	Torch cup is loose, safety contact pins dirty or not making contact with cup face. Torch switch wire is loose. Problem with connector. Torch is not properly connected.
Amperage changes constantly, "bouncing" back and forth wildly, randomly.	Some variance is normal. When Pilot arc lights, amps drop until arc is transferred. Check connections.
Unstable Arc at lower amps.	Consumable orifice size is too large. Reduce orifice size.
Arc tries to start but irregular, dancing arc and/or arc melts through side of nozzle.	Missing swirl ring, or worn electrode or both. Check and replace. Make sure swirl ring is not cracked.
Arc will try to start if touched to the metal, but no air flow while switch is pressed.	Stuck or dirty solenoid valve. Contact Everlast. Wrong Process selected.
Air flows continuously.	Post flow turned set too long. Preflow is turned on. Solenoid is stuck. Contact Everlast.
Excessively Beveled Cut.	Worn consumables, too high of stand-off height.
Cup and/or nozzle is melting or cracking.	Improper cutting technique/excessive piercing.
Power input circuit breaker trips repeatedly.	Improperly sized circuit. Internal issue. Contact Everlast.
Arc "Blows Out" when ready to cut.	Too high of air pressure. Reduce to 55-65 psi.
Arc will not stop when switch is released.	Torch trigger is stuck.

