

EVERLAST PRODUCTS

OWNER'S MANUAL

Everlast CT416/518/630D

DC TIG/MMA Welder

with Plasma Cutter

EVERLAST

www.everlastgenerators.com

Email: everlast_inc@hotmail.com

Phone: 650-588-8588 x201

Support: www.everlastgenerators.com

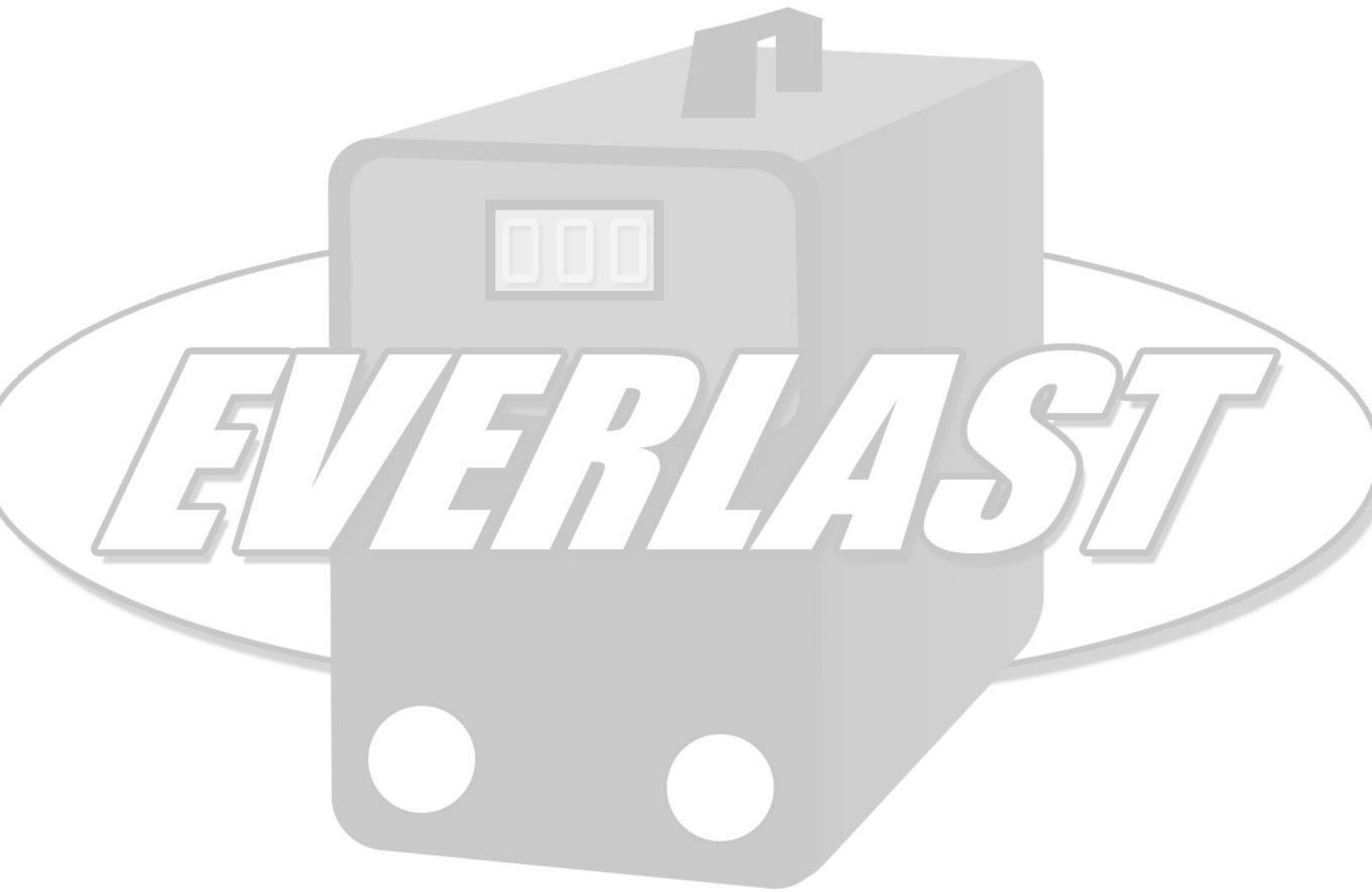

CONTENTS

- Warning.....	2
- General Description.....	3
- Installation & Operation.....	4
- Hookup and checks	5
- General Operations	6
- Caution.....	8
- Maintenance.....	9
- Troubleshooting.....	10
- About Welding.....	11
- FAQ (wiring plug, TIG torch info, electrodes, etc).....	13

This welding equipment is for industrial and professional use in conformity with IEC 60974 International Safety Standard.

We offer a five-year warranty on our welders and cutters starting on the date of purchase.

Please read and understand the instruction manual carefully before the installation and operation of this product.

The contents of this manual may be revised without prior notice and without obligation. This instruction manual was issued July 2008.

WARNING

Welding and plasma cutting is dangerous. Not just to the equipment operator, but people nearby and the surrounding area with the sparks and electrical power. Therefore, the use of this equipment must only be under the most strict and comprehensive observance of all relevant safety rules. Please read and understand this instruction manual carefully before installing and operating this product.

NOTICE:

Switching between functions (TIG/MMA/Plasma) should not be done while you are welding or cutting as this can damage the equipment. Do not disconnect the electrodes-torches or ground clamp cable from the equipment while the unit is in use or powered on.

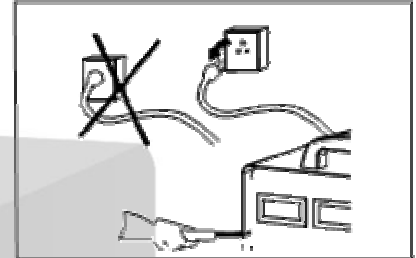

Electric Shock can be fatal

Always connect the earth ground clamp to your work piece. Avoid "all" contact with live components of the welding circuit, electrodes/torches and wires with bare hands or skin. It is necessary for the operator to wear dry welding gloves while welding or cutting. The operator should keep the working piece insulated from themselves at all time.



Smoke and Gases generated while welding or cutting can be harmful to your health.

Avoid breathing the smoke and gases when welding or cutting. Keep the working area well ventilation. Warn others as well. Keep pets out of the area as well.

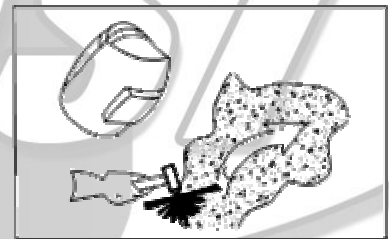

Arc light-emissions are harmful to people's eyes and skin.

Wear approved welding helmet, anti-radiation glass and work clothes while welding and cutting. Measures must be taken to protect people/pets in or near the working area as well.



Fire hazards

The welding splash and sparks can cause a fire, remove flammable materials away from the welding and cutting work area. Have a fire extinguisher nearby at all times and a trained person ready to use it.

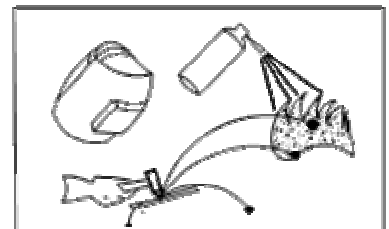

Noise from the unit can possibly harm your hearing.

Surface noise is generated while welding and cutting, ear protection is necessary in some cases.



Machine fault or failure

Consult this instruction manual first. Then contact your local EVERLAST dealer or supplier for further advice.



GENERAL DESCRIPTION

The newly-developed EVERLAST CT-D series DC TIG, MMA and Plasma cutter allows welding stainless steel, alloy steel and carbon steel and other nonferrous metals. The power exchange rate of these models are over 85% efficient which will save your power usage and provide for cleaner welds and cuts.

The design and development of our state-of-the-art Inverter technology used in our welders and cutters, allows for the high power output with its solid state MOS-FET (Metal Oxide Semi-conductor Field Effect Transistors). With high quality MOS-FET output components, these TIG welding units can function with a HF (high frequency) of 100KHz, thus reducing the size and weight of the main components (transformers). The application of PWM (Pulse Width Modulation) technology enables the concentration and stability of the output current (AMPS) and with much more precise and convenient current control. The unique structural design enables the disassembly and maintenance of these unit and maximizes EMI.

With the exclusive HF Inverter technology of the Everlast CT-D series, in comparison to traditional welding equipment, you have more advantages, as it is much smaller in size, lighter in weight, higher in power exchange rate; in comparison to the imported welding equipment. Being a single phase unit, it can be used through-out the world.

Note: An optional foot pedal controller is available, which allows the modulation of your output current while using your welder. This is available for the Everlast CT-D series; improving welding efficiency and performance.

Block Diagram:

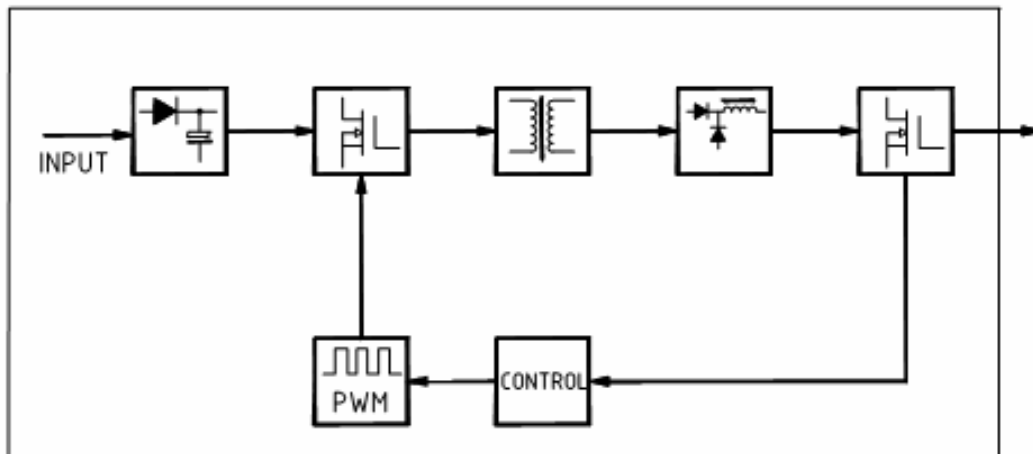

INSTALLATION AND OPERATION

- 1. Power Cord :** The power cord is attached to the unit, however you will be required to provide a power plug and power outlet. This is to accommodate different countries and setups. Please contact an electrician if you are not qualified or not sure how to attach an AC plug. See FAQ for more information on wiring.
- 2. Connecting the Torches and Cutter (front of unit):**
 - 2a: MMA clamp**, connect the MMA stick torch/clamp to the 2a fast-plug and turn it clockwise.
 - 2b: TIG torch**, also plug the seven pin plug connector 2c from the TIG torch or the “optional” foot pedal into its socket, attach/ screw the TIG torch to “GAS” outlet. Fasten the collar nuts, *see the diagram below*.
 - 2b: Plasma torch** will connect the same as the TIG just using the Plasma torch rather than the TIG torch. *Make sure you connect COMPRESSED AIR for Plasma operation OR Argon for TIG operation. Not doing so could damage the unit or consumables.*
 - 2c: Torch on off control or optional foot pedal control.**
 - 2d: IN ALL modes mentioned above** the fast-plug on the black ground clamp cable needs to be plugged into 2d socket on the front panel, and turn it in the clockwise direction. Then the ground clamp connects to your work piece.

SWITCHES

- 3. Main power switch:** The power switch. When “ON” this switch will light up and you will hear the fans turn on. *If not see troubleshooting section.*
- 4. MMA/TIG/Plasma mode switch:** MMA is for stick/MMA welding. TIG is for DC TIG welding and Plasma for cutting.
- 5. AIR FLOW DELAY:** This switch sets the pre and post argon gas or air flow delay.
- 6. AMP settings:** This control sets the welding amperage (outer scale) and Plasma cutter amperage (inner scale)
- 7. Machine/Pedal switch:** This switch tell the welder if you are using the torch on/off switch or optional foot pedal.

INDICATORS

- 8. O.C./Over Current:** This light will turn on in the event the units overheats due to long periods of use at high current. It is there to protect the unit. If you see this light “on”, “stop” welding/cutting but leave the unit “ON” for the fans to cool it. Wait for the light to go “off” before you continue welding. If it does not go off please contact the manufacturer for help.



Hookup and checks

- 1) With automatic voltage fluctuation control, this welder will function despite the input voltage exceeding 15% of the nominal voltage or a loss of up to 15% of nominal voltage.
- 2) If you increase the length of the leads, be aware that possible machine damage can occur with excessively long leads.
- 3) Make sure the gas/air supply is always available for the operation (plasma or TIG) you are working with. Connect the Argon gas supply for TIG or compressed air for plasma. Make certain the connection and pressure is correct (see about welding for more information).
- 4) Ground the unit with 6mm² (10 gauge) wire to the earth ground.
- 5) Connect the power cord, torch and earth ground clamp (see drawing below).
- 6) If you've followed all we have written, you should be ready to weld. Weld safely please...

Thank you for your time and support, Everlast Products.

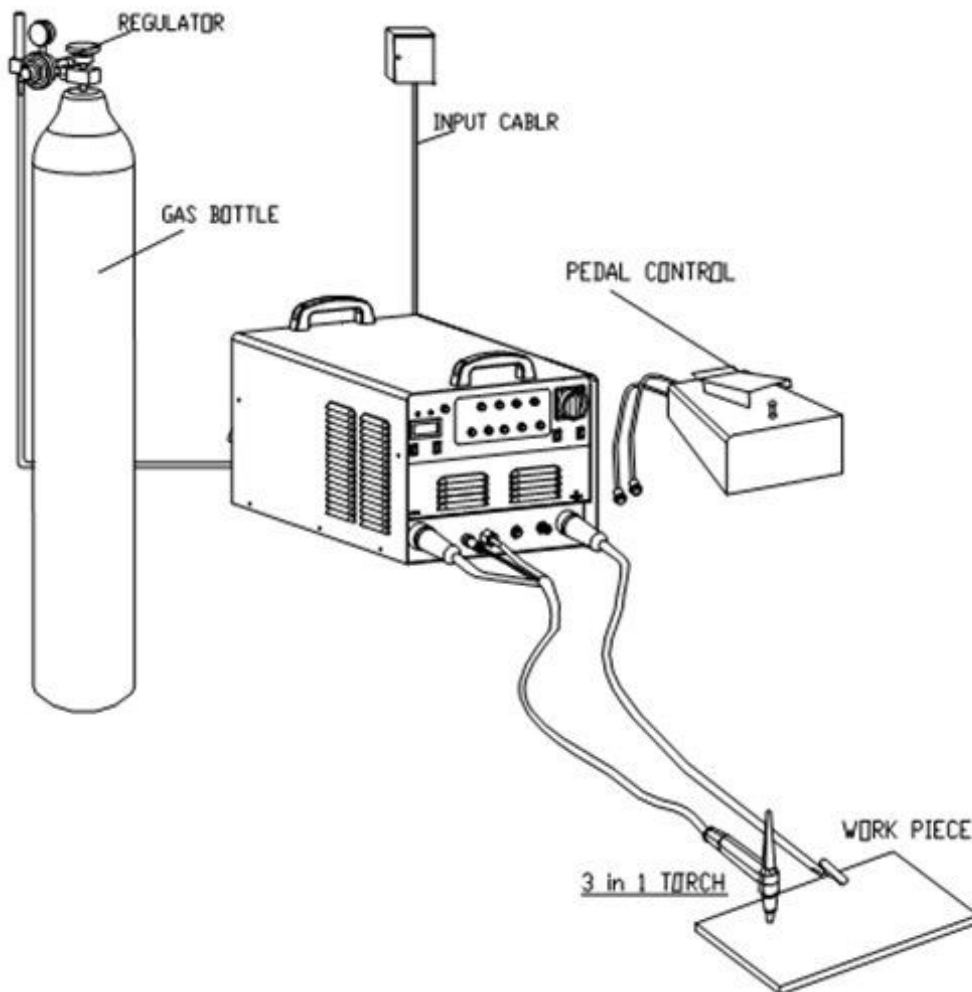

GENERAL OPERATION

DC TIG INSTRUCTIONS (Steel and Stainless)

1. Set the operation mode switch (switch 4 on page 4) to TIG.
2. Set your amperage (switch 6 on page 4) to your desired welding amperage.
3. Set the argon regulator (15-20cfh).
4. Set the pre/post flow switch to 2.5 seconds or 5 seconds. 5 seconds for thicker steel.
5. Hook your ground clamp to the work piece.
6. Switch ON the welding unit (switch 3 on page 4).
7. Press the torch switch or optional foot pedal, an electromagnetic valves will click on, HF electricity should be auditable and gas output presents.

Note: When starting with a new TIG session, press the switch on the welding torch for several seconds to completely fill the hose with argon gas (purging any air out). At this point you are ready to weld. After welding; the post gas output continue for several seconds to protect the weld.

8. **If using the optional foot pedal controller.** Adjust the welding AMPS on the front panel to 0. The welding amperage will be adjustable with the pedal controller.
9. The distance between tungsten and work pieces should be in the range of 2mm to 4mm (1/8" to 1/4"). Press the switch of welding torch, you will hear and see HF electricity between the tungsten and work pieces. Start your puddle and use your filler rod to fill it.

MMA/Stick welding (AC or DC)

1. Set the mode to MMA.
2. Connect the MMA torch as mentioned on page 4 section 2
3. Set your AMPS as desired (for the thickness of your work pieces)
4. Turn on the MAIN power, no other settings are required, you are ready to stick weld. See the "about welding" section for more details and learning how to strike your arc.

GENERAL OPERATION *(continued)*

PLASMA CUTTER INSTRUCTIONS

1. Set the operation mode switch to CUT (see page 4 for a diagram).
2. Connect the Plasma torch as shown on page 4 section 2 (same as MMA just a different torch)
3. Set your AMPS as desired (for the thickness of your work piece) AND AIR PRESSURE (65 PSI)
4. Turn on the MAIN power, no other settings are required, you are ready cut.

Note: There are many ways to plasma cut. Always use extreme caution and the proper protection. Always blow the melted metals away from you. You can either get close to the work piece with the torch tip to start the arc or drag the side of the torch tip for dragging and cutting. The internet has many websites that will explain Plasma cutting as this is an instructional manual, be sure to search the internet for methods and example projects.

CAUTIONS

1. Working Environment

- 1.1 The location in which this welding equipment is installed should be of little dust, corrosive chemical gas, flammable gas or materials etc, and of maximum 80% humidity
- 1.2 Avoid the operation of welding in the open air unless the working area is sheltered from the sunshine, rain water and snow etc; the temperature of working environment should be maintained within -10°C to +40°C;
- 1.3 Keep this cutting equipment 2' or more from the wall or obstacle .
- 1.4 Only work in a well ventilated area.

Safety Tips

- 2.1 Ventilation: This cutting equipment is small-sized, compact in structure, and has excellent performance in amperage output. The fans are only to extract heat generated by its internal electronics. Make sure your cutting area is well ventilated and use proper protection (breathing protection if required).

Cautions: Make sure the louvers (vents) on the equipment as always clear of obstructions. Good ventilation is critical for the proper performance and service life of this cutting equipment.

2.2 O.C. Overload

If a sudden halt occurs while cutting or welding and the O.C. (over current) light comes on, simply stop welding. Do not turn off the unit or restart it either. Leave the unit ON and allow the internal fans to bring down the temperature inside the equipment. Continue when the O.C. light goes out.

2.3 Over-voltage

Regarding the power supply voltage range of the equipment, refer to the Main parameter tables (page 6 and 7). This cutting equipment has automatic voltage compensation in the power supply, which allows it to operate within the given ranges listed there. In case that the voltage exceeds the stipulated value, it is possibly damaging to the components of this equipment.

- 2.4 An earth terminal ground should be used if required and available. Connect the earth ground cable to avoid the static and electric shock.

- 2.5 DO NOT ever contact the output terminals (torch and ground) when welding or cutting. An electric shock will occur.

Keep SAFETY as number one, you are working with voltage, high amperage, sparks and gas.

CAUTIONS

1. The Working Environment

- 1.1 The location in which this welding equipment is installed should have little dust, corrosive chemical fumes, flammable gas, and of maximum 80% humidity .
- 1.2 Avoid welding in the outside unless the working area sheltered from the sunshine, rain and snow; the temperature of working environment should be maintained within -50°F to $+120^{\circ}\text{F}$;
- 1.3 Keep this equipment 12 inches from any walls or obstructions.
- 1.4 Keep the working environment “well” ventilated.

2. Safety Tips

2.1 Ventilation of equipment

This equipment is compact and can produce high output amperage. The fans are to extract the heat generated by this equipments internal circuits while in operation. Maintain good ventilation of the louvers of this equipment. The minimum distance between this equipment and any other objects in or near the working area should be no less that 12 inches. Good ventilation is of critical importance for the normal performance and service life of your unit.

2.2 If you ever over heat!

If a sudden over occurs while using this equipment and the O.C. light turns one. Stop cutting or welding and allow the fans to cool the unit until the O.C. light turns off. Do not turn the unit off, as the fan will help cool it faster.

2.3 Input voltage!

Make sure you provide a 240vac 50-60Hz input with 30 amps of power to this unit. This equipment has automatic voltage compensation, which enables the unit to work given proper voltage, current and frequency if provided. If improper input power is not used, it is possible to damage the components of the unit.

- 2.4 Make sure the green ground wire on the power line and plug are connected to ground, the other two are to connect to 120vac hot legs for 240vac operation. There is no neutral in this case. Connecting the earth ground is to avoid the electrical shock.

- 2.5 **NEVER** contact the output terminals when the welding. An electric shock can possibly occur if you are in contact a ground with another part of your body (bare feet as well makes a great ground).

MAINTENANCE

Exposure to extremely dusty, damp, or corrosive air can be damaging to this equipment. In order to prevent a future possible failure, clean any dust on regular intervals with clean, dry compressed air of a reasonable pressure.

On the plasma torch, keep the nozzle clean/clear. Check and make sure the internal electrode is not worn, if so replace it. Everlast sells large packs of consumables at a very low price.

On the TIG, check and sharpen your tungsten as needed (see about welding).

Be careful not to drop the torches as the ceramic cups can crack or break.

Keep the unit out of direct sunlight as the Sun's UV can fade the paint and knobs.

Please note: The lack of reasonable maintenance/care can void your warranty. The warranty of this equipment will be cancelled if the unit has been abused or opened without the consent of an Everlast Products technician.

Circuit Diagram

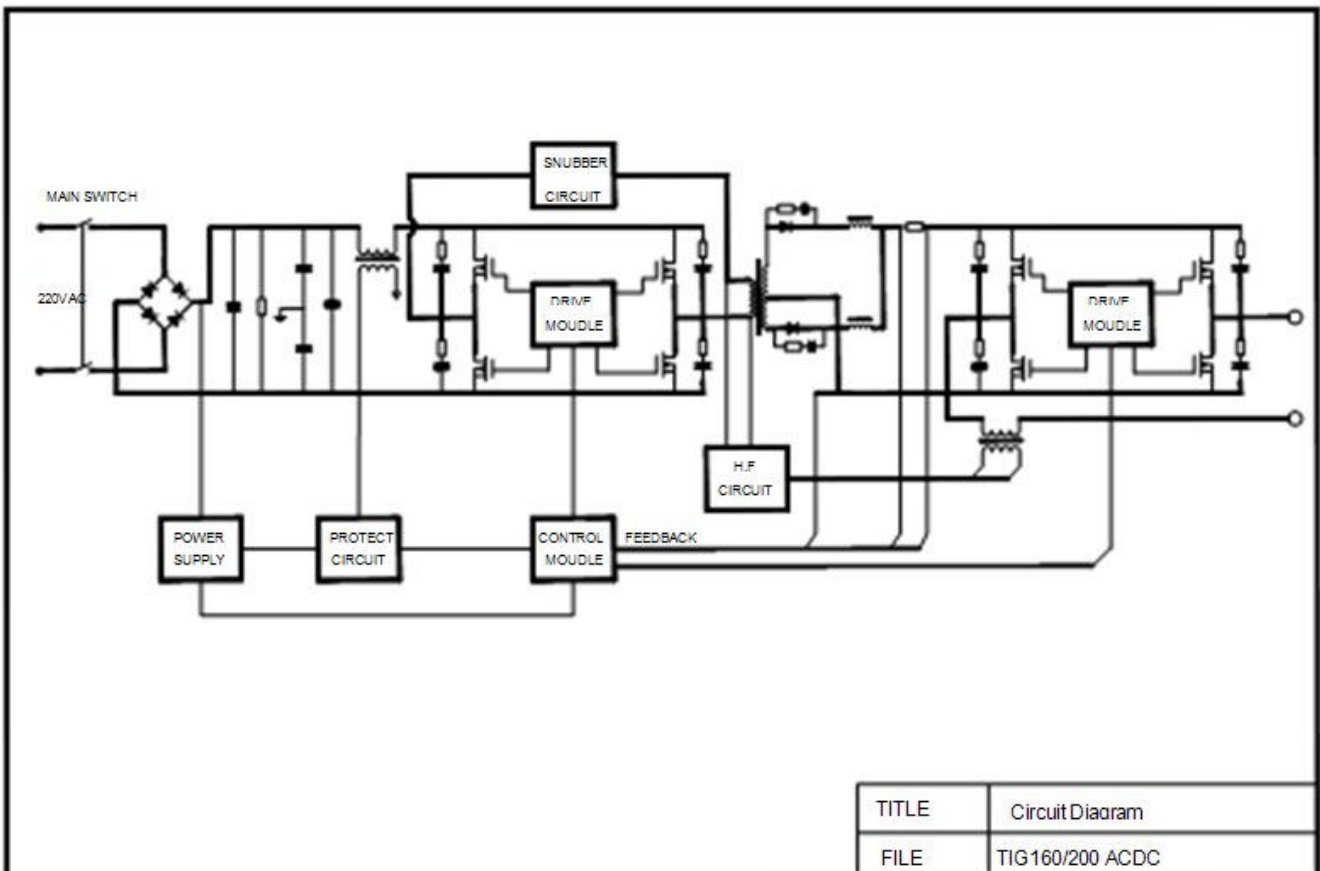

TROUBLESHOOTING

Caution: For safety reasons only qualified technicians are allowed to work on this unit if there's an electrical failure. Below is a trouble shooting matrix . If the scope is a welding issue, you can use these tables to assist you in your troubleshooting. We recommend under all circumstance you should contact your authorized Everlast dealer or take this manual and your unit (if out of warranty) to a certified professional and have them diagnose the unit.

Troubleshooting matrix chart

Symptoms	Possible Causes	Corrective Action
Main power switch is on, no power light or display.	<ol style="list-style-type: none"> 1. No AC power to the unit from the wall outlet 2. Insufficient power to the unit 3. Internal power supply failure or blown fuse 	<ol style="list-style-type: none"> 1. Make sure you have voltage going to the units power cord. 2. Correct voltage issue 3. Contact your Everlast dealer
Can not weld or cut but the power light is on and display is working.	<ol style="list-style-type: none"> 1. Low voltage on the main power . 2. HF circuit is not running right 	<ol style="list-style-type: none"> 1. Check the power and make sure it is within specs. 2. Call for tech support
O.C. light on when switched on	<ol style="list-style-type: none"> 1. Electrode is shorted 	<ol style="list-style-type: none"> 1. Remove and clean or replace the electrode and nozzle(s)
Power switch will not turn on OR power switch will not turn off	<ol style="list-style-type: none"> 1. Bad power switch 	<ol style="list-style-type: none"> 1. Call Everlast for a replacement switch. Note the wire colors when you replace the switch
No air sound when using plasma or TIG welding modes	<ol style="list-style-type: none"> 1. Gas or air compressor is not getting to the unit, check regulator or gas/air supply 2. Bad gas switch in the unit 	<ol style="list-style-type: none"> 1. Correct gas flow to the unit, air on, tank on and regulator settings 2. Call Everlast for instruction
Torch switch works, foot pedal does not	<ol style="list-style-type: none"> 1. Foot pedal is not plugged in or pedal knob is not set 2. Foot pedal controller is bad 	<ol style="list-style-type: none"> 1. Reconnect and set the knob on the pedal 2. Call Everlast

ABOUT WELDING

At this point you should have read the previous pages, know how to hook up the torches and ground, set the operating mode, and hookup the right gas or air. We cannot possibly teach you to be a welder or all the options you have with the Everlast unit, but here we will offer some tips in each area to get you started.

NOTE AGAIN: Smoke from metals, flux and gases are simply bad for your health. Galvanized and zinc plated metals should not be used *at all*. If you need these type metals welded, take them to a local professional welding shop. Assuming that you've read about the eye protection, clothing, fire and electrical hazards, let's move on. Please read all the sections here as they may have little tips that might not be in the others.

Plasma cutting:

The Plasma torch. This torch has an electrode inside, cup and air nozzle. The torch comes assembled, so take it apart and you can see how to replace parts later, they just screw in. Get them on snug but do not over tighten them.

Inspect the electrodes each use, if it is ever pitted or worn, replace it. If your electrode is pitted, you're probably touching the work piece while cutting. Practice will prevent this as you learn to keep the cutter just off the work piece.

There are a couple methods of plasma cutting, one is called the drag cut and this can all be googled for as well as the others (thank you google.com). So we will spend very little time on technique for plasma cutting as it is quite simple.

Always make sure you have compressed air connected when cutting, 60-70 PSI at 3CFM should be connected to the rear of the units air input nipple. If you do not supply the compressed air it can damage the cutter. Do a test cut and make sure the melted metal is blowing through your work piece. If the cut is too wide, lower your current. You can use other thick steel and a C-clamp, as a straight edge to make your cuts straight and nice.

Make sure you aim the cutter away from you as you cut to blow the molten metal away from you. And last on all these areas make sure you wear the proper long sleeves, gloves, leathers, shoes and shield.

General items for welding:

General tools you will need, slag/chipping hammer for MMA, a stainless steel wire brushes, a grinder, files, C clamps. You will find other tools you need as you learn. You will need flux coated rods for MMA welding, rods and tungsten electrodes for the DC TIG welding.

For TIG, the tungsten is not included with the welder and is "not a consumable" (well as you start welding for the first time, it might be). So you will need to go to a local welding store for these items. After we cover MMA and TIG we will outline some rods you might want to start with and tungsten types/sizes, also how to sharpen your tungsten.

NOTE: With MMA AND TIG it is VERY IMPORTANT to clean the joints (work pieces) before you weld. All rust/oxidation and paint must be removed. I like to wipe everything down with denatured alcohol afterward. If it is not clean, the weld will be weak and can break, and you do not want this on your kids bike, a trailer, a car, etc.

MMA/Stick welding:

The MMA clamp/torch has 0/45/90 degree slot to hold your welding rod. Just clamp in the rod at the angle that will be easiest to use for the position you need to weld. Set the amperage, lower for thin steel, higher for thick. You can order good books on welding with charts on rods, pressures, and amperage. We are just giving you a kick start, this is not a welders manual by any means.

With MMA you must strike the rod to start the welding process. This takes practice. So do not plan on welding something important until you have gathered some small scrap steel and have practiced. There is no gas required, the flux on the rod acts as the gas to protect the metal. Just the torch/clamp, ground clamp and filler rod.

Do not turn the welder on until you are ready to weld. Then strike the arc like a match on the work piece, after the arc is going you have to keep the rod 1/8" to 1/4" over the area to be welded or the arc will stop. This type welding will take a lot of practice, but when proficient, you will be able to do a lot with MMA. MMA is quick and requires no gas. You can go to a local welding shop for 6010 or 6013 rod to start welding steel. And 308 rod for stainless steel. Your local welding shop will steer you right, do not demand what I say, this is what works well for me.

ABOUT WELDING (continued)

TIG welding in general:

TIG welding requires an inert gas, 100% Argon or an Argon mix (start with 100% Argon if you are new to welding). So you will need a tank of Argon to hook to the gas inlet on the back of the unit. Put a fitting so you can swap the air compressor for your Plasma cuts and Argon tank. Hint, get one size bigger on the argon tank as it costs about the same to get twice as much on the refill.

TIG also requires a tungsten electrode (not included). The argon and electrode are not parts you would get with any welder. So you "will" need to visit the welding store before you TIG. TIG welding will give you the best control over your welds, keep the heat right on the area you want to weld (reduces warping), and probably give you the strongest weld if done right (ok all welds are strong if done right). TIG will look nicer over all electrical welding methods. Even as a novice you can make a nice bead with some practice.

As far as the tungsten electrodes, there are two general types and a few different sizes (diameter). The first type is the (green tip) "pure tungsten" for aluminum TIG AC welding and the (red tip) "tungsten 2% thoriated" for TIG DC or pulsed steel and stainless steel welding. I will list what I use here shortly, but let's get back to the Everlast Super series TIG.

With your supplies you will see you have 1/16, 3/32, 1/8 inch collets to allow for different electrode sizes. You might have larger in your set. I keep 1/16 and 1/8 inch for steel (thoriated/red; steel DC welding;). 3/32 and 1/8 inch pure tungsten for aluminum (green). They are 7" long.

Before you install the tungsten electrode you will need to sharpen the tips. The point taper should be 2.5 time the diameter on the electrode tip as a general rule. The steel tungsten electrodes (red tip) should be sharpened to a very sharp point on the end and sharpened with the length of the rod not across the point. Aluminum you want a ball on the end (if it's not a perfect ball, it will be after you use it, so that is not so critical). And it should be sharpened with the length as well. Now let's see how to put the electrode in the torch.

On the top (back side) of your torch you will have the short black "back" cap and in the accessory bag you will see a longer black "back" cap, which is for the 7" electrodes you picked up at the welding store. Along with the longer back cap, there are ceramic cups (pink) of varying sizes 5-7 to output the shielding Argon gas. The larger the cup the better (unless you are doing small gauge flat metals). The smaller cups and short back cap are for welding in tight areas so you can get the torch in tight spots. (you will need to cut an electrode down to use the short back cap). On the bottom of the torch you have the cup (pink ceramic). This sends the gas out to protect the metal from oxidation as you weld (heat) the metals. Also in the bag there are collets for the different size diameter tungsten electrodes you can use.

If you have sharpened your tungsten electrode, unscrew the short back cup shipped on the torch (and get the larger long back cap from the bag). Take out the collet inside the torch (under the back cap; the cap pushes the collet to lock your tungsten electrode in place). Match your electrode with the correct collet size. Insert the collet and tungsten electrode and put on the long back cap and start to tighten. Make sure you have from 1/8 to 1/4 inch of the tungsten electrode sticking out below the bottom of the (pink) cup. At this point you have the gas hooked up, the torch ready for steel or aluminum. You will want to set your Argon gauge from 10-25 cfh (cubic feet per hour). I normally shoot for 20.

To set the gas pressure gauge you will have to press the torch switch or pedal and waste a little gas, but you need to purge the air from the line anyway..

TIG DC

If you reference page 7 (TIG DC) of this manual, it has the setup information for DC TIG. Use this to set your control panel. DC TIG is good for steel, stainless and carbon steel. Your tungsten electrode (red tip; thoriated) should have a sharp point. With a longer point, you have a more precise and narrow TIG arc. As mentioned above, set your gas to 20cfh, the controls, prep (clean) your work pieces, clamp them together and connect the ground clamp. At this point you are ready to TIG. Start by evenly heating the two parts you want to weld. Watch for a pool of metal to form. When you see the pool and glow, you are ready to dip the rod in the pool and remove it. You then move the torch and repeat this operation. You might want to tack weld each end first so you can remove the clamps and then run your bead.

If you are right handed, use the torch in your right hand and the left to dip the (308 stainless steel or W-1200 steel) filler rod you purchased in the type work piece you are welding.

FAQ (frequently asked questions)

(Q) How do I wire my units power cord and plug?

(A) All EVERLAST units work with 220volts AC (it's always recommend using 220VAC), some units will work with 110VAC. Make sure you have a 110VAC unit before trying to run your unit on 110VAC. It's VERY HARD to miss-wire your unit as long as you hook the **green or green/yellow GROUND** wire to the **ground terminal** on your power plug **first**. See the diagram that came with your power plug and **PLEASE make sure the power its OFF**. After you connect the **GROUND** wire to the **ground terminal**, connect the two remaining hot wires to the two remaining terminals, one wire to one terminal, the other wire to the other terminal.

Note: Be sure to checked the unit specs for power and amperage of your power plug, outlet and circuit breaker size. If you use a 4 terminal 200VAC plug (for generator compatibility), NEUTRAL is NEVER used on 220VAC plugs and operation.

If you're not qualified to wire the unit, please hire an professional electrician.

When wiring for 220VAC, first connect the ground wire to the ground terminal (see the diagram that came with your plug), then connect the two hot wires to the other two remaining terminals (you can connect either wire to either terminal).

When wiring a 110VAC unit for 110VAC operation, wire the ground first (as with the 220VAC), then the other two wires to the remaining two terminals on the 110VAC plug. The unit will automatically adjust for neutral as there is a neutral prong on a 110VAC plug.

An example of a 4 prong 220VAC/30AMP twist lock plug wired for 220VAC (we will not use neutral; 4th prong (W)). Only the X and Y (hot mains) and GROUND (GREEN). If you use a three prong 220VAC plug, a neutral will not be present or needed. Start by wiring GREEN GROUND wire to the ground terminal after sliding on your cap and seal (see below right).

Make sure there are no frayed wires and the plug terminals are tight.



Above left is a 4 prong male plug (250VAC/30AMP), plug cap, rubber cap seal and the cord from the welder. Use this same procedure on 3 prong (250VAC) plugs (there's no neutral on the 250VAC "three" prong plugs). The above right picture shows the seal and cap on the cord and the ground wire connected to the ground terminal, note the green on the ground terminal (green wire goes there).

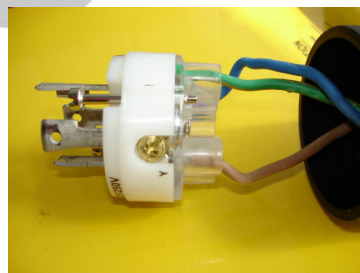

Above left is a 4 prong male plug (250VAC/30AMP), plug cap, rubber cap seal and the cord from the welder. Use this same procedure on 3 prong (250VAC) plugs (there's no neutral on the 250VAC "three" prong plugs). The above right picture shows the seal and cap on the cord and the ground wire connected to the ground terminal, note the green on the ground terminal (green wire goes there).

FAQ (frequently asked questions continued)

Still not sure how to wire the plug? Let's cover more on AC wiring and the type wires and plugs. This is not to make anyone an electrician. If you are unsure of the wiring, hire a professional and be safe.

Standard US 110volts AC is normally 3 wires, a black (hot), white (neutral) and green (ground). EVERLAST welders have a brown (hot), blue (neutral) and green (ground).

On the dual voltage units, the brown is the black and blue is the white. But make sure you have a dual voltage unit if you want to run on 110volts AC. Also, note the current your welder/cutter will pull. Again, we recommend 220volts AC wiring, and 30 AMPs, but if you want to work with what you have you must be responsible for the power you draw from the outlet. After this is said. **DO NOT USE 110VAC UNLESS YOU KNOW WHAT YOU'RE DOING!**

110 volts AC wiring (not recommended, 220vac 30 amp minimum)

110VAC 15AMP
(way to small)

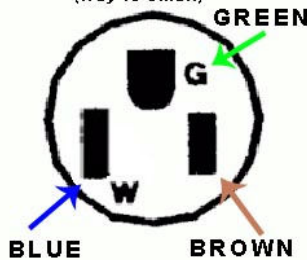

110VAC 20AMP

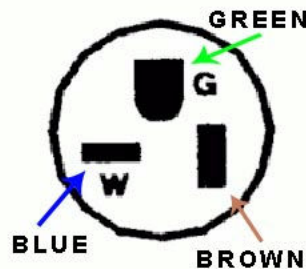

110volts AC 20AMP twist

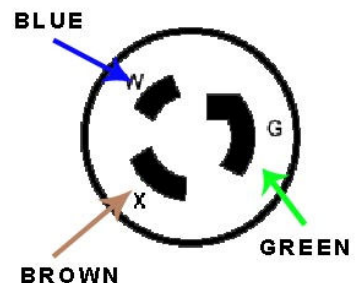

220 volts AC wiring

220VAC 20AMP twist

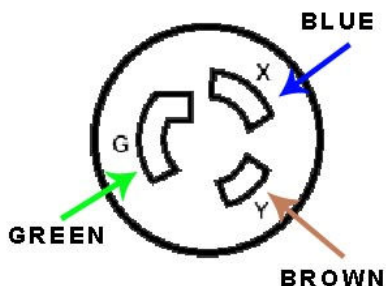

220VAC 30AMP LOCK

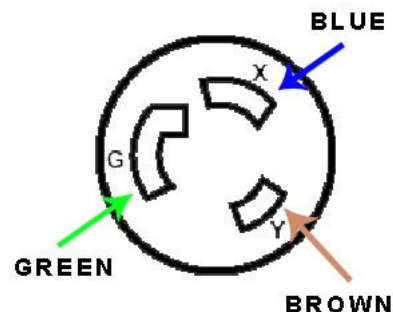

FAQ (frequently asked questions continued)

(Q) How do I setup my TIG torch?

(A) The TIG torch comes with shield cups (pink), collets (copper) and caps (black screw in plugs with o-ring). You will need to provide the argon gas tank (and 20cfh) and the tungsten electrode (from a local welding store). The two caps, a short cap (flat cap) for close tight work (you will have to cut an electrode down for it) and a long cap (7" standard electrodes, you will use to start your TIG welding). Collet sizes are labeled on the collet as to what size electrodes they will lock in the torch. Again, use the largest shield cup when you can. Small collets and electrodes are for thin narrow welds and larger ones for thicker/wider welds. Read the "About welding" to learn the red (steel/stainless) type tungsten electrode and how to sharpen the end of the electrode.



This is how the torch looks once you have it assembled. The tungsten is about 1/8" to 1/4" out from the shield cup.

Sharpened as per the "About Welding" section for the metal you wish to weld with the 2% Thoriated tungsten. The points and taper on the point will affect your width of your weld.

This is a breakdown of the TIG torch. The tungsten (non-consumable) is not included and the type tungsten is based on the type metal you wish to weld.

This view shows how the parts insert into each other and the torch handle. The tungsten size should match the collet size, cup wide as you can go (I like 7) for good gas flow (low oxidation). The shield cup screws on rounded side up and the cap (short or long) screws in the top to lock the tungsten electrode tight. Short cap is not pictured but it is a flat cap for tight welding spots, you should start off with the long cap.

FAQ (frequently asked questions continued)

(Q) What type Tungsten Electrodes do I need for what type metal and how to I sharpen it?

(A) Read “About Welding” again for the details, here are pictures of the brand I use and sizes. You can ask your local Welding store what they like.



With this unit, you will use the RED tips (2% thoriated) for steel and stainless. The green in the picture are for use with the Super P series welders.

Red tip (2% thoriated) need a very sharp point for steel and stainless (DC TIG). The longer the points, the finer the arc. So sharpen the Tungsten to a shape point and the taper length should be 2.5 time the diameter of the electrode.

A note from Everlast Products.

This is a new manual for the Super160/200/250P and ACDC TIG 160/200 products. It can be used with the TIG product line if you ignore the plasma cutter sections.

We hope you like the new version. The “About Welding” section is new as well as the FAQ that will grow as questions come into our technical support group. We will make updates to it on an on going bases. We will have updates on the everlastgenerators.com website via a link.

Please send any recommendations or corrections (as we know some professionals use our units).

Thank you for your purchase, and spread the word about Everlast products.

Email: everlast_inc@hotmail.com

Phone: 650-588-8588 x201

Support: everlastgenerators.com



EVERLAST