

EVERLAST

POWERPRO 164



Operator's Manual for the PowerPro 164 Safety, Setup and General Use Guide

everlastwelders.com

Rev. 2 0 00501-14



1-877-755-9353
329 Littlefield Ave. South San Francisco, CA 94080 USA

Specifications and Accessories subject to change without notice.

TABLE OF CONTENTS

Section.....	Page
Letter to the Customer	3
Everlast Contact Information.....	4
Safety Precautions.....	5
Introduction and Specifications.....	9
Unit Specifications.....	10
General Overview.....	11
General Use and Care.....	11
Quick Setup Guide, TIG Torch/Cooler Connection	12
Quick Setup Guide, Plasma Connection.....	13
Quick Setup Guide, Stick Polarity and Connection	14
Quick Setup Guide, Rear Connection for Plasma...	15
Quick Setup Guide, Rear Connection for TIG.....	16
Front Panel Features and Controls.....	17
Rear Panel Features and Controls.....	20
Welder Function Summary and Explanations.....	22
Tungsten Preparation.....	26
High Frequency Start TIG Operation.....	27
Plasma Function and Operation.....	29
Recommendations for Polarity/Amps/Tungsten..	33
Expanded View of TIG torch.....	34
PowerPro 164 Plasma Torch S-45.....	35
7 Pin Connector Pin-out.....	36
Troubleshooting.....	37

NOTE: Product Specifications and features are subject to change without notice. While every attempt has been made to provide the most accurate and current information possible at the time of publication, this manual is intended to be a general guide and not intended to be exhaustive in its content regarding safety, welding, or the operation/maintenance of this unit. Everlast Power Equipment INC. does not guarantee the accuracy, completeness, authority or authenticity of the information contained within this manual. The owner of this product assumes all liability for its use and maintenance. Everlast Power Equipment INC. does not warrant this product or this document for fitness for any particular purpose, for performance/accuracy or for suitability of application. Furthermore, Everlast Power Equipment INC. does not accept liability for injury or damages, consequential or incidental, resulting from the use of this product or resulting from the content found in this document or accept claims by a third party of such liability.

Dear Customer,

THANKS! You had a choice, and you bought an Everlast. We appreciate you as a customer and hope that you will enjoy years of use from your welder.

Please go directly to the Everlast website to register your unit and receive your warranty information. Your unit registration is important should any information such as product updates or recalls be issued. It is also important so that we may track your satisfaction with Everlast products and services. If you are unable to register by website, contact Everlast directly through the sales department through the main customer service number in your country. Your unit will be registered and warranty will be issued and in full effect. Keep all information regarding your purchase. **In the event of a problem you must contact technical support before your welder can be a candidate for warranty service and returned.**

Please review the current online warranty statement and information found on the website of the Everlast division located in or nearest to your country. Print it for your records and become familiar of its terms and conditions.

Everlast offers full technical support, in several different forms. We have online support available through email, and a welding support forum designed for customers and noncustomer interaction. Technical advisors are active on the forum daily. We also divide our support into two divisions: technical and welding performance. Should you have an issue or question concerning your unit, please contact performance/technical support available through the main company headquarters available in your country. For best service call the appropriate support line and follow up with an email, particularly during off hours, or in the event you cannot reach a live person. In the event you do not reach a live person, particularly during heavy call volume times, holidays, and off hours, leave a message and your call will normally be returned within 24 hours. Also, for quick answers to your basic questions, join the company owned forum available through the website. You'll find knowledgeable, helpful people and staff available to answer your questions, and perhaps find a topic that already addresses your question at <http://www.everlastgenerators.com/forums/>.

Should you need to call or write, always know your model name, purchase date and welder manufacturing inspection date. This will assure the quick and accurate customer service. **REMEMBER: Be as specific and informed as possible. Technical and performance advisors rely upon you to carefully describe the conditions and circumstances of your problem or question. Take notes of any issues as best you can. You may be asked many questions by the advisors to clarify problems or issues that may seem very basic. However, diagnosis procedures MUST be followed to begin the warranty process. Advisors can't assume anything, even with experienced users, and must cover all aspects to properly diagnose the problem. Depending upon your issue, it is advisable to have basic tools handy such as screwdrivers, wrenches, pliers, and even an inexpensive test meter with volt/ohm functions before you call.**

Let us know how we may be of service to you should you have any questions.

Sincerely,

Everlast Customer Service

Serial number: _____

Model number: _____

Date of Purchase _____

EVERLAST

Contact Information

Everlast US:

Everlast consumer satisfaction email: sales@everlastwelders.com

Everlast Website: everlastwelders.com

Everlast Technical Support: support@everlastwelders.com

Everlast Support Forum: <http://www.everlastgenerators.com/forums/index.php>

Main toll free number: 1-877-755 WELD (9353) 9am—5pm PST M-F

11am-4pm PST Sat.

FAX: 1-650-588-8817

Everlast Canada:

Everlast consumer satisfaction email: sales@everlastwelders.ca

Everlast Website: everlastwelders.ca

Everlast Technical Support: sales@everlastwelders.ca

Telephone: 905-637-1637 9am-4:30pm EST M-F

10am-1pm EST Sat.

FAX: 1-905-639-2817

Everlast Australia:

Sydney: 5A Karloo Parade Newport NSW 2106

(02) 9999 2949

Port Macquarie: 2B Pandorea Place Port Macquarie

(02) 8209 3389

After hours support: 0413 447 492

Everlast Technical Support: support@pickproducts.com

SAFETY PRECAUTIONS

Everlast is dedicated to providing you with the best possible equipment and service to meet the demanding jobs that you have. We want to go beyond delivering a satisfactory product to you. That is the reason we offer technical support to assist you with your needs should an occasion occur. With proper use and care your product should deliver years of trouble free service.



Safe operation and proper maintenance is your responsibility.

We have compiled this operator's manual, to instruct you in basic safety, operation and maintenance of your Everlast product to give you the best possible experience. Much of welding and cutting is based upon experience and common sense. As thorough as this welding manual may be, it is no substitute for either. Exercise extreme caution and care in all activities related to welding or cutting. Your safety, health and even life depends upon it. While accidents are never planned, preventing an accident requires careful planning.

Please carefully read this manual before you operate your Everlast unit. This manual is not only for the use of the machine, but to assist in obtaining the best performance out of your unit. Do not operate the unit until you have read this manual and you are thoroughly familiar with the safe operation of the unit. If you feel you need more information please contact Everlast Support.

The warranty does not cover improper use, maintenance or consumables. **Do not attempt to alter or defeat any piece or part of your unit, particularly any safety device.** Keep all shields and covers in place during unit operation should an unlikely failure of internal components result in the possible presence of sparks and explosions. If a failure occurs, discontinue further use until malfunctioning parts or accessories have been repaired or replaced by qualified personnel.



Note on High Frequency electromagnetic disturbances:

Certain welding and cutting processes generate High Frequency (HF) waves. These waves may disturb sensitive electronic equipment such as televisions, radios, computers, cell phones, and related equipment. High Frequency may also interfere with fluorescent lights. Consult with a *licensed* electrician if disturbance is noted. Sometimes, improper wire routing or poor shielding may be the cause.



HF can interfere with pacemakers. See EMF warnings in following safety section for further information. Always consult your physician before entering an area known to have welding or cutting equipment if you have a pacemaker.

SAFETY PRECAUTIONS



These safety precautions are for protection of safety and health. Failure to follow these guidelines may result in serious injury or death. Be careful to read and follow all cautions and warnings. Protect yourself and others.



Welding and cutting processes produce high levels of ultraviolet (UV) radiation that can cause severe skin burn and damage. There are other potential hazards involved with welding such as severe burns and respiratory related illnesses. Therefore observe the following to minimize potential accidents and injury:



Use appropriate safety glasses with wrap around shields while in the work area, even under welding helmets to protect your eyes from flying sparks and debris. When chipping slag or grinding, goggles and face shields may be required.



When welding or cutting, always use an approved shielding device, with the correct shade of filter installed. Always use a welding helmet in good condition. Discard any broken or cracked filters or helmets. Using broken or cracked filters or helmets can cause severe eye injury and burn. Filter shades of no less than shade 5 for cutting and no less than shade 9 for welding are highly recommended. Shades greater than 9 may be required for high amperage welds. Keep filter lenses clean and clear for maximum visibility. It is also advisable to consult with your eye doctor should you wear contacts for corrective vision before you wear them while welding.



Do not allow personnel to watch or observe the welding or cutting operation unless fully protected by a filter screen, protective curtains or equivalent protective equipment. If no protection is available, exclude them from the work area. Even brief exposure to the rays from the welding arc can damage unprotected eyes.



Always wear hearing protection because welding and cutting can be extremely noisy. Ear protection is necessary to prevent hearing loss. Even prolonged low levels of noise has been known to create long term hearing damage. Hearing protection also further protects against hot sparks and debris from entering the ear canal and doing harm.



Always wear personal protective clothing. Flame proof clothing is required at all times. Sparks and hot metal can lodge in pockets, hems and cuffs. Make sure loose clothing is tucked in neatly. Leather aprons and jackets are recommended. Suitable welding jackets and coats may be purchased made from fire proof material from welding supply stores. Discard any burned or frayed clothing. Keep clothing away from oil, grease and flammable liquids.



Leather boots or steel toed leather boots with rubber bottoms are required for adequate foot protection. Canvas, polyester and other man made materials often found in shoes will either burn or melt. Rubber or other non conductive soles are necessary to help protect from electrical shock.



Flame proof and insulated gauntlet gloves are required whether welding or cutting or handling metal. Simple work gloves for the garden or chore work are not sufficient. Gauntlet type welding gloves are available from your local welding supply companies. Never attempt to weld with out gloves. Welding with out gloves can result in serious burns and electrical shock. If your hand or body parts comes into contact with the arc of a plasma cutter or welder, instant and serious burns will occur. **Proper hand protection is required at all times when working with welding or cutting machines!**

SAFETY PRECAUTIONS



WARNING! Persons with pacemakers should not weld, cut or be in the welding area until they consult with their physician. Some pacemakers are sensitive to EMF radiation and could severely malfunction while welding or while being in the vicinity of someone welding. *Serious injury or death may occur!*



Welding and plasma cutting processes generate electro-magnetic fields and radiation. While the effects of EMF radiation are not known, it is suspected that there may be some harm from long term exposure to electromagnetic fields. Therefore, certain precautions should be taken to minimize exposure:

- Lay welding leads and lines neatly away from the body.
- Never coil cables around the body.
- Secure cables with tape if necessary to keep from the body.
- Keep all cables and leads on the same side the body.
- Never stand between cables or leads.
- Keep as far away from the power source (welder) as possible while welding.
- Never stand between the ground clamp and the torch.
- Keep the ground clamp grounded as close to the weld or cut as possible.



Welding and cutting processes pose certain inhalation risks. Be sure to follow any guidelines from your chosen consumable and electrode suppliers regarding possible need for respiratory equipment while welding or cutting. Always weld with adequate ventilation. Never weld in closed rooms or confined spaces. Fumes and gases released while welding or cutting may be poisonous. Take precautions at all times. Any burning of the eyes, nose or throat are signs that you need to increase ventilation.

- Stop immediately and relocate work if necessary until adequate ventilation is obtained.
- Stop work completely and seek medical help if irritation and discomfort persists.



WARNING! Do not weld on galvanized steel, stainless steel, beryllium, titanium, copper, cadmium, lead or zinc without proper respiratory equipment and or ventilation.



WARNING! This product when used for welding or cutting produces fumes and gases which contains chemicals known to the State of California to cause birth defects and in some cases cancer. (California Safety and Health Code §25249.5 *et seq.*)



WARNING! Do not weld or cut around Chlorinated solvents or degreasing areas. Release of Phosgene gas can be deadly. Consider all chemicals to have potential deadly results if welded on or near metal containing residual amounts of chemicals.



Keep all cylinders upright and chained to a wall or appropriate holding pen. Certain regulations regarding high pressure cylinders can be obtained from OSHA or local regulatory agency. Consult also with your welding supply company in your area for further recommendations. The regulatory changes are frequent so keep informed.



All cylinders have a potential explosion hazard. When not in use, keep capped and closed. Store chained so that overturn is not likely. Transporting cylinders incorrectly can lead to an explosion. Do not attempt to adapt regulators to fit cylinders. Do not use faulty regulators. Do not allow cylinders to come into contact with work piece or work. Do not weld or strike arcs on cylinders. Keep cylinders away from direct heat, flame and sparks.

SAFETY PRECAUTIONS

continued



WARNING! Electrical shock can kill. Make sure all electrical equipment is properly grounded. Do not use frayed, cut or otherwise damaged cables and leads. Do not stand, lean or rest on ground clamp. Do not stand in water or damp areas while welding or cutting. Keep work surface dry. Do not use welder or plasma cutter in the rain or in extremely humid conditions. Use dry rubber soled shoes and dry gloves when welding or cutting to insulate against electrical shock. Turn machine on or off only with gloved hand. Keep all parts of the body insulated from work, and work tables. Keep away from direct contact with skin against work. If tight or close quarters necessitates standing or resting on work piece, insulate with dry boards and rubber mats designed to insulate the body from direct contact.



All work cables, leads, and hoses pose trip hazards. Be aware of their location and make sure all personnel in area are advised of their location. Taping or securing cables with appropriate restraints can help reduce trips and falls.



WARNING! Fire and explosions are real risks while welding or cutting. Always keep fire extinguishers close by and additionally a water hose or bucket of sand. Periodically check work area for smoldering embers or smoke. It is a good idea to have someone help watch for possible fires while you are welding. Sparks and hot metal may travel a long distance. They may go into cracks in walls and floors and start a fire that would not be immediately visible. Here are some things you can do to reduce the possibility of fire or explosion:

- Keep all combustible materials including rags and spare clothing away from area.
- Keep all flammable fuels and liquids stored separately from work area.
- Visually inspect work area when job is completed for the slightest traces of smoke or embers.
- If welding or cutting outside, make sure you are in a cleared off area, free from dry tender and debris that might start a forest or grass fire.
- Do not weld on tanks, drums or barrels that are closed, pressurized or anything that held flammable liquid or material.



Metal is hot after welding or cutting! Always use gloves and or tongs when handling hot pieces of metal. Remember to place hot metal on fire-proof surfaces after handling. Serious burns and injury can result if material is improperly handled.



WARNING! Faulty or poorly maintained equipment can cause injury or death. Proper maintenance is your responsibility. Make sure all equipment is properly maintained and serviced by qualified personnel. Do not abuse or misuse equipment. Keep all covers in place. A faulty machine may shoot sparks or may have exploding parts. Touching uncovered parts inside machine can cause discharge of high amounts of electricity. **Do not allow employees to operate poorly serviced equipment.** Always check condition of equipment thoroughly before start up. Disconnect unit from power source before any service attempt is made and for long term storage or electrical storms.



Further information can be obtained from The American Welding Society (AWS) that relates directly to safe welding and plasma cutting. Additionally, your local welding supply company may have additional pamphlets available concerning their products. Do not operate machinery until you are comfortable with proper operation and are able to assume inherent risks of cutting or welding.

PowerPRO 164



Air Cooled 26 series 12 ft.



Trafimet (or other maker) S-45
12 ft. Plasma Torch



Work Clamp

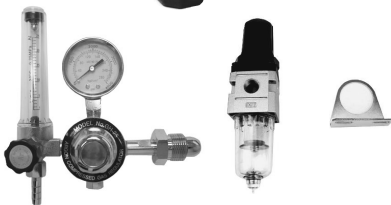

Argon and Air Regulator



Consumable Starter Kit
(Does not include Tungsten)



47K Ω
Foot Pedal Assembly



Stick Electrode Holder

NOTE: Accessory and consumable style and quantities are subject to change without notice. Consumable starter kits provide only enough consumables to get you started. Extra consumables can be purchased through Everlast or almost any local welding supply store.

PowerPro 164	SPECIFICATION
Process	AC/DC GTAW-P/DC SMAW/PAC
Inverter Type	Analog, Fairchild IGBT (non module)
Minimum/Maximum Rated Output TIG 120/240v	DC: 120 V: 5 A/10.2 V—25 A/ 15.0 V 240 V: 5 A/10.2 V — 60A/ 16.4 V AC: 120 V: 20 A/ 10.8V — 125A/ 15.0 V 240 V: 20 A/10.8 V — 160A/ 16.4 V
Minimum/Maximum Rated Output Stick 120/240V	120V V: 5A/20.2V—90A/ 23.6 V 240V 5 A/20.2 V—130 A/ 23.6 V
Minimum/Maximum Rated Output Plasma 120/240V	120 V: 20 A/88V—25 A/90V 240V: 20 A/88V—40 A/ 96V
Start Type	HF only
HF Point Gap	.030”-.045” (.035” suggested)
TIG Duty Cycle @ Rated Amps/Volts	120 V: 60% @ 125 A/15V 100% @ 100 A/14V 240 V: 60% @ 160 A/16.4 V 100% @ 130 A/ 15.2 V
Stick Duty Cycle @ Rated Amps/Volts	120 V: 60% @ 90A/23.6 V 100% @ 75 A/ 23 V 240 V: 60% @ 130 A/ 25.2 V 100% @ 100 A/ 24 V
Plasma Duty Cycle @ Rated Amps/Volts	120 V: 60% @ 25 A/ 90 V 100% @ 20 A/88V 240 V: 60% @ 40 A/ 96 V 100 % @ 30 A/92 V
OCV (U0)	70 V
Voltage Input (U1)	110/120 V, 220/240 V; 50/60 Hz 1 Ph
Maximum Inrush Amps (I1MAX)	31 A @ 110V/ 25A @ 220 V / 23A @ 240 V
Maximum Operating Amps (Rated Effective) (I1EFF)	25 A @ 110 V/ 21A @ 220 V/18 A @ 240 V
Post Flow Time	0-10 Seconds
Down Slope	0-10 Seconds
AC Frequency Control	20-250 Hz
AC Balance Control	10-90% of Electrode Positive (EP)
Pulse Frequency Hz (Pulses Per Second)	1 or 25Hz
Minimum Water Ingress Protection Standard	IP21S
Efficiency	>85%
Cooling Method	Full time High Velocity Fan with Tunnel design.
Dimensions (approximate)	18” H X 10” X 25” L
Weight (Bare Unit)	68 lbs.

The minimum size required to run this unit on 220V is 5500 watts. Use this unit only with generators that are certified as clean power by the manufacturer of the generator (defined as less than 10% total harmonic distortion). Use of this product with generators that are not clean power rated or underpowered is prohibited and will void the warranty.

SECTION 1

INTRODUCTION AND SPECIFICATIONS

General overview: The PowerPro 164 from Everlast is designed as a TIG/Stick welder and a plasma cutter fitted into one relatively compact package. It is designed with portable repair in mind. It is a great go-anywhere unit, at the track or in the field. It features convenience and affordability. The unit is ideal for many typical repair situations where on-the-spot repair is necessary.

- A. Dual voltage design makes it truly portable and versatile. 125 Amp TIG/Stick and 25 Amp Plasma output on 120V input.
- B. Full bridge design features soft switching technology which further extends IGBT component life and extends its capabilities.
- C. Improved HF point design offers better and more stable arc starts, even at lower amperages.
- D. Features automatic over-voltage, over current and duty cycle protection (over-heat).
- E. The square wave design creates a stable arc in AC, with a fast melting puddle and good wet in.
- F. New, improved design offers more intuitive adjustments, and provides better panel protection.

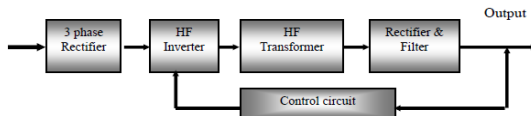

Basic Inverter design

General Use and Care: The welder is designed for regular use, but not necessarily for fabrication or production duties. Keep in mind that the unit is designed for on-the-spot repairs and portability. They provide function and convenience in these situations. Care should be taken to keep the unit out of direct contact with water spray. The unit is rated IP21S, which rates it for light contact with dripping water. It is a good idea to remove the welder from the vicinity of any water or moisture source to reduce the possibility of electrocution or shock. Never operate in standing water.

Every 1-2 months, depending upon use, the welder should be unplugged, opened up and carefully cleaned with compressed air. Regular maintenance will extend the life of the unit.

! IMPORTANT: Before opening the unit for any reason, make sure the unit has been unplugged for at least 10 minutes to allow time for the capacitors to fully discharge. Severe shock and/or death can occur.

Do not restrict air flow or movement of air around the welder. Allow a buffer distance of 2 ft from all sides if possible, with a minimum distance of at least 18" clear-

ance. Do not operate the welder immediately in the weld area or the force of the fan will cause welding issues such as unstable arc, or porosity.

Do not mount in areas that are prone to severe shock or vibration. Lift and carry the welder by the handle.

Do not direct metallic dust or any dirt intentionally toward the machine, particularly in grinding and welding operations. Make sure the panel is protected from damage during welding and cutting operations by flipping down the clear protective cover.

Duty Cycle. The duty cycle has been determined for the PowerPro 164 at 160 A @ 60% duty cycle for TIG and Stick. The duty cycle is based off a 10 minute duty cycle rating at 40° C. This means that the unit is capable of being operated at the max amps for the stated percent of time out of 10 minutes without a break to cool down the unit. For the remainder of the 10 minute time period, the welder should rest for maximum life. The temperature light will come on and the welder will automatically stop welding when an overheat condition has occurred. Stop welding immediately. Heat will continue to be generated by and transferred to the electronics after welding has ceased. Welding in humid, or hot conditions can affect duty cycle as well. Do not shut down an overheated welder until it has safely cooled. Once the overheated condition has cleared, welding can resume. Do not operate the welder with the covers removed. Only cycle the power switch to reset the unit IF the light has not gone out after 10 minutes.

HF Start. The welder uses High Frequency to start the TIG arc. HF is generated by a point gap system similar to an older automotive point/coil system. A slight buzz, or hiss may be heard immediately upon start as the HF energizes. A bright blue light may be emitted from the front or side panel as the spark energizes. This is normal and safe as long as the covers are in place.

This manual has been compiled to give an overview of operation and is designed to offer information centered around safe, practical use of the welder. Welding is inherently dangerous. Only YOU, the operator of this welder, can ensure that safe operating practices are followed, through the exercise of common sense practices and training. Do not operate this machine until you have fully read the manual, including the safety section. If you think that you do not have the skill or knowledge to safely operate this welder, do not use this welder until formal training is received.

QUICK SETUP GUIDE: TIG CONNECTIONS

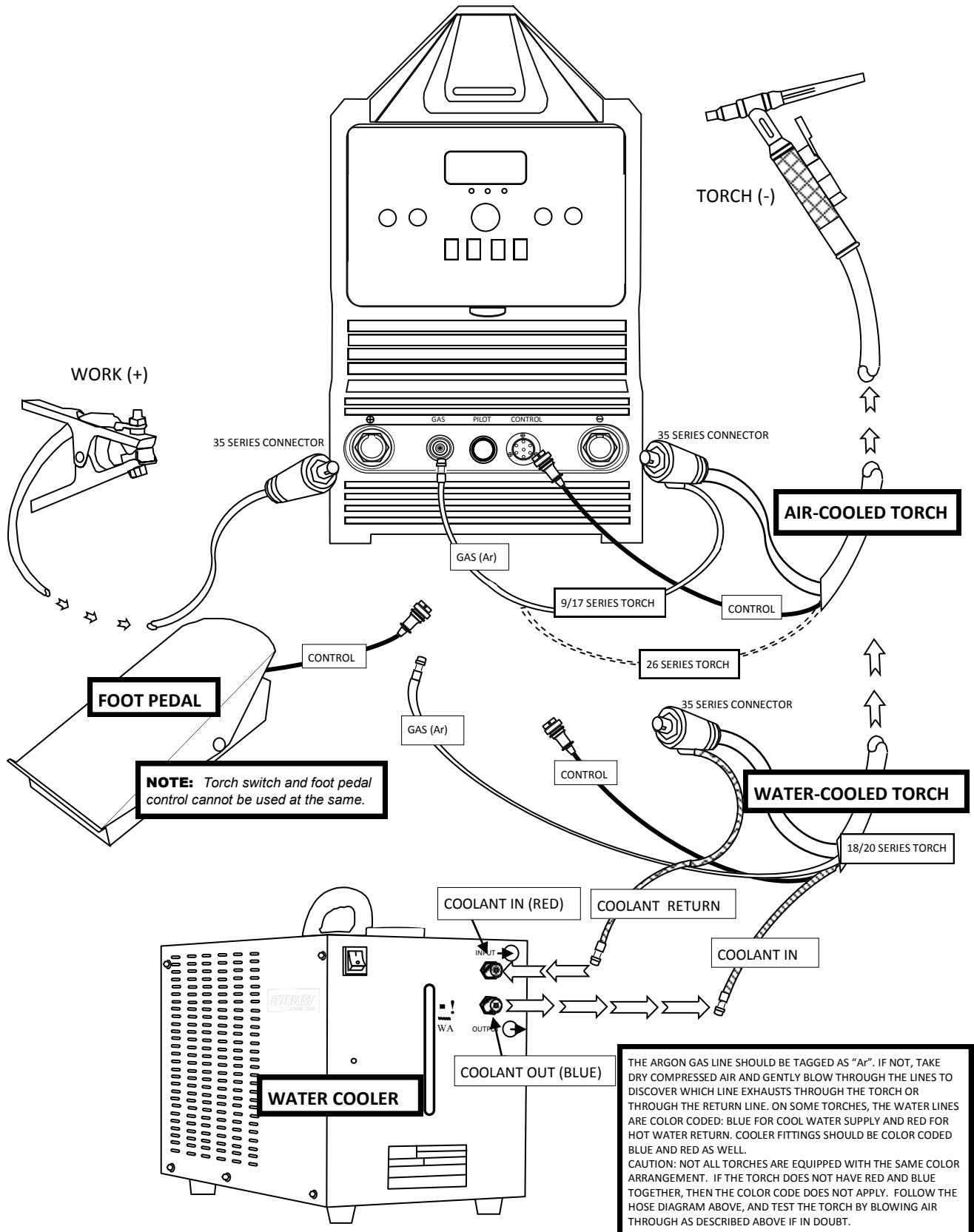

QUICK SETUP GUIDE: PLASMA CONNECTIONS

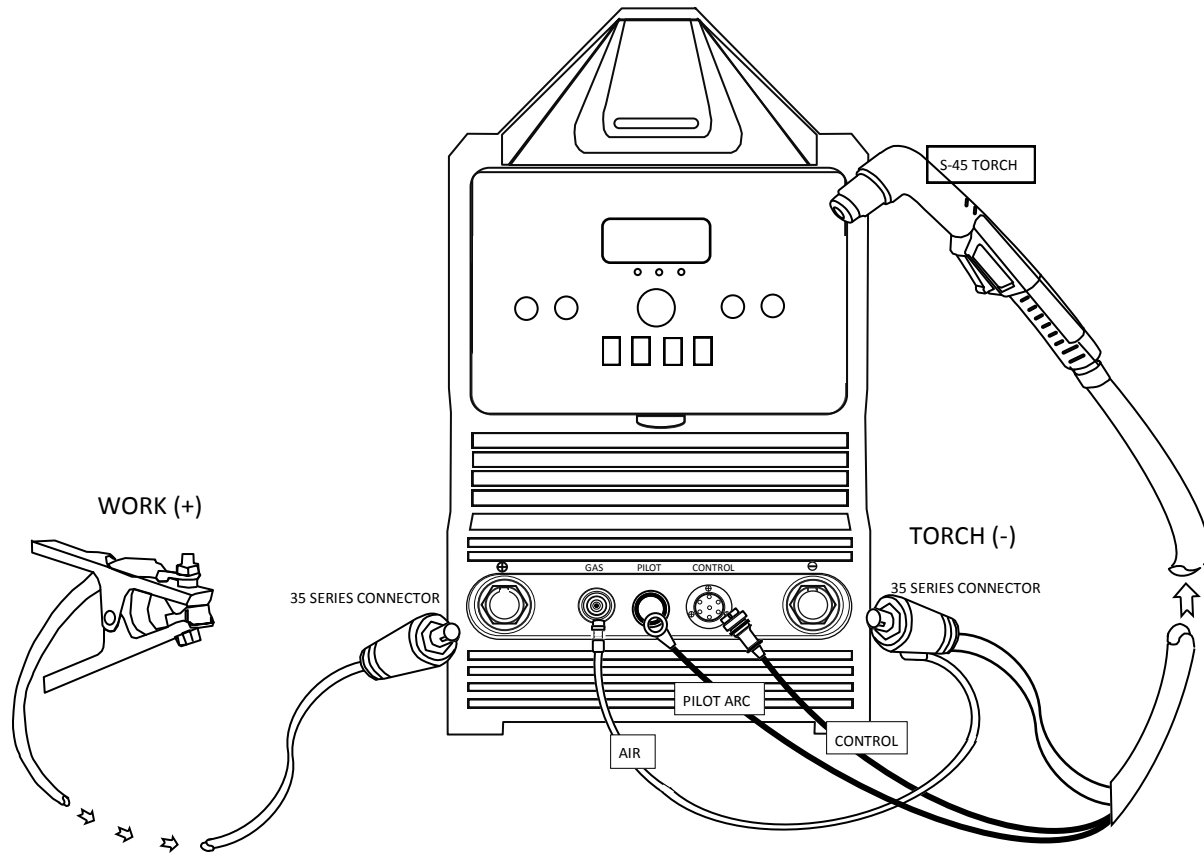

NOTES:

- 1) When connecting and using the plasma function of the unit, be sure to always turn off the pulse function. Set post flow for about 1 second for every 10 amps. Operate only in DC mode. AC is not used to cut aluminum!
- 2) For operation, and safest use, be sure 2T is selected. Do not attempt to use the foot pedal to control the amps.
- 3) Do not flip the process switch while cutting or unit failure may result.
- 4) Attempt to operate only when "OK to Cut" light is ON.
- 5) See torch manual included in this manual for best pressure settings and parts identification.
- 6) Do not exceed 90 psi air supply pressure or failure of components may result.
- 7) Adjust torch operation pressure to 72 psi (5 bar) for best results while post flow is flowing. If supplied, use the flow meter as depicted in the torch manual to properly set the air pressure and flow.*
- 8) When using lower amperage levels, the nozzles will need to be changed out for ones with a smaller diameter orifice. Everlast is the OEM supplier of the torch but not the manufacturer. Smaller diameter nozzles are available through Trafimet authorized distributors.
- 9) Be sure to unscrew the pilot arc thumb nut and attach the wire with the eyelet to this location before attempting operation. Tighten only finger tight! Do not use pliers. The pilot arc will not work without this connection.

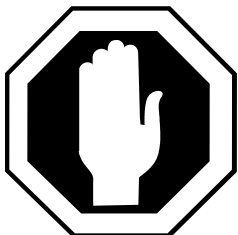

***WARNING: DO NOT PUT THE AIR FLOW METER ON THE END OF THE TORCH AND FIRE THE TORCH OR THE TORCH WILL ENGAGE THE PILOT ARC AND MELT THE METER. SERIOUS BURN OR INJURY MAY RESULT! TO USE CORRECTLY: SET POST FLOW TO MAXIMUM AND FIRE THE TORCH BRIEFLY. RELEASE THE TRIGGER, TO START THE POST FLOW. THEN PLACE THE FLOW METER OVER THE END OF THE TORCH. USE THE POST FLOW TIME TO ADJUST THE AIR PRESSURE. IF POST FLOW STOPS, REMOVE THE AIR FLOW METER FROM THE TIP OF THE TORCH AND REPEAT THE TEST, USING THE POSTFLOW CYCLE TIME TO MAKE NECESSARY ADJUSTMENTS.**

QUICK SETUP GUIDE: STICK POLARITY AND CONNECTIONS

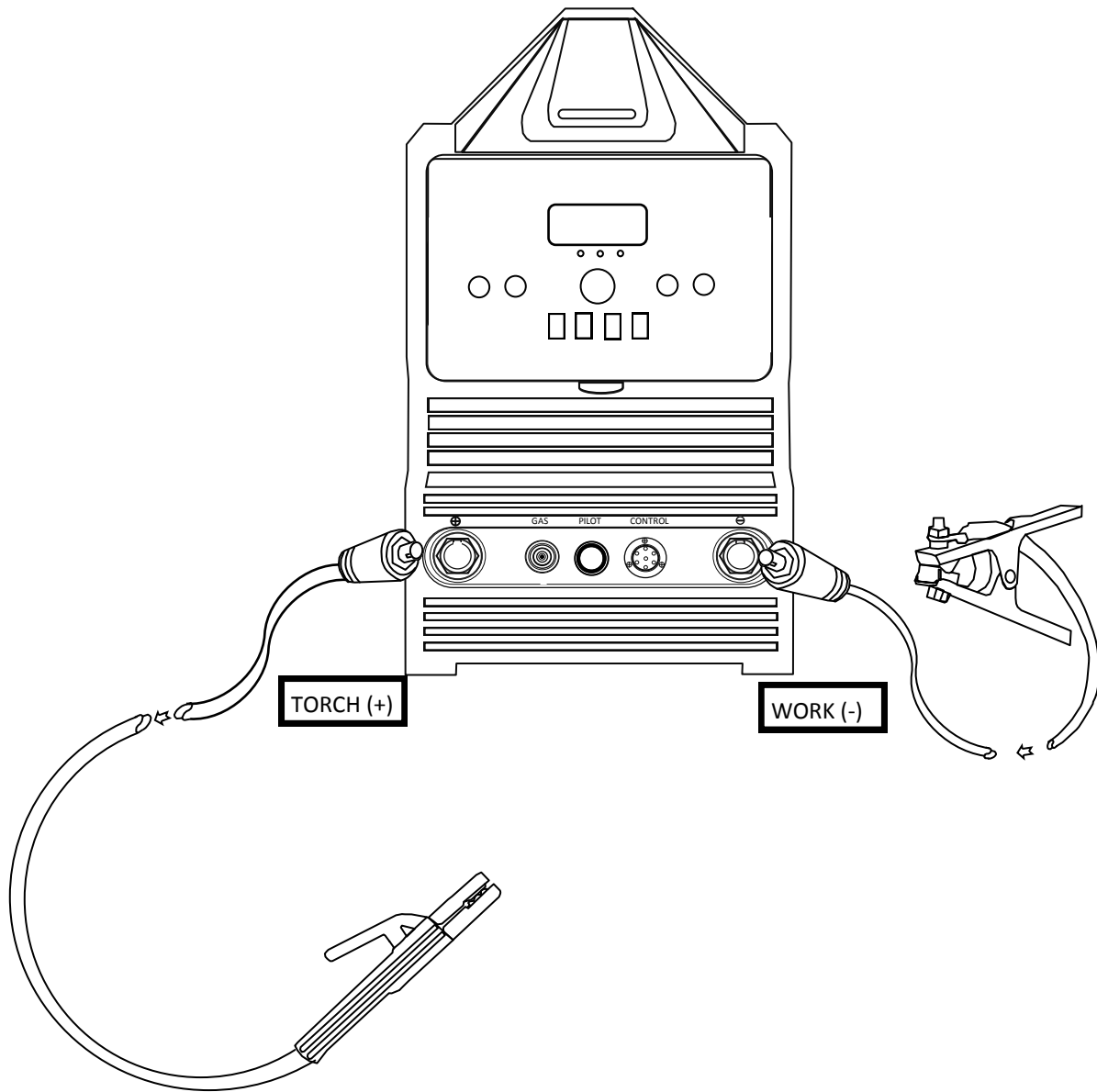

**QUICK SETUP GUIDE: REAR CONNECTIONS FOR PLASMA OPERATION
Compressor and Dryer Diagram**

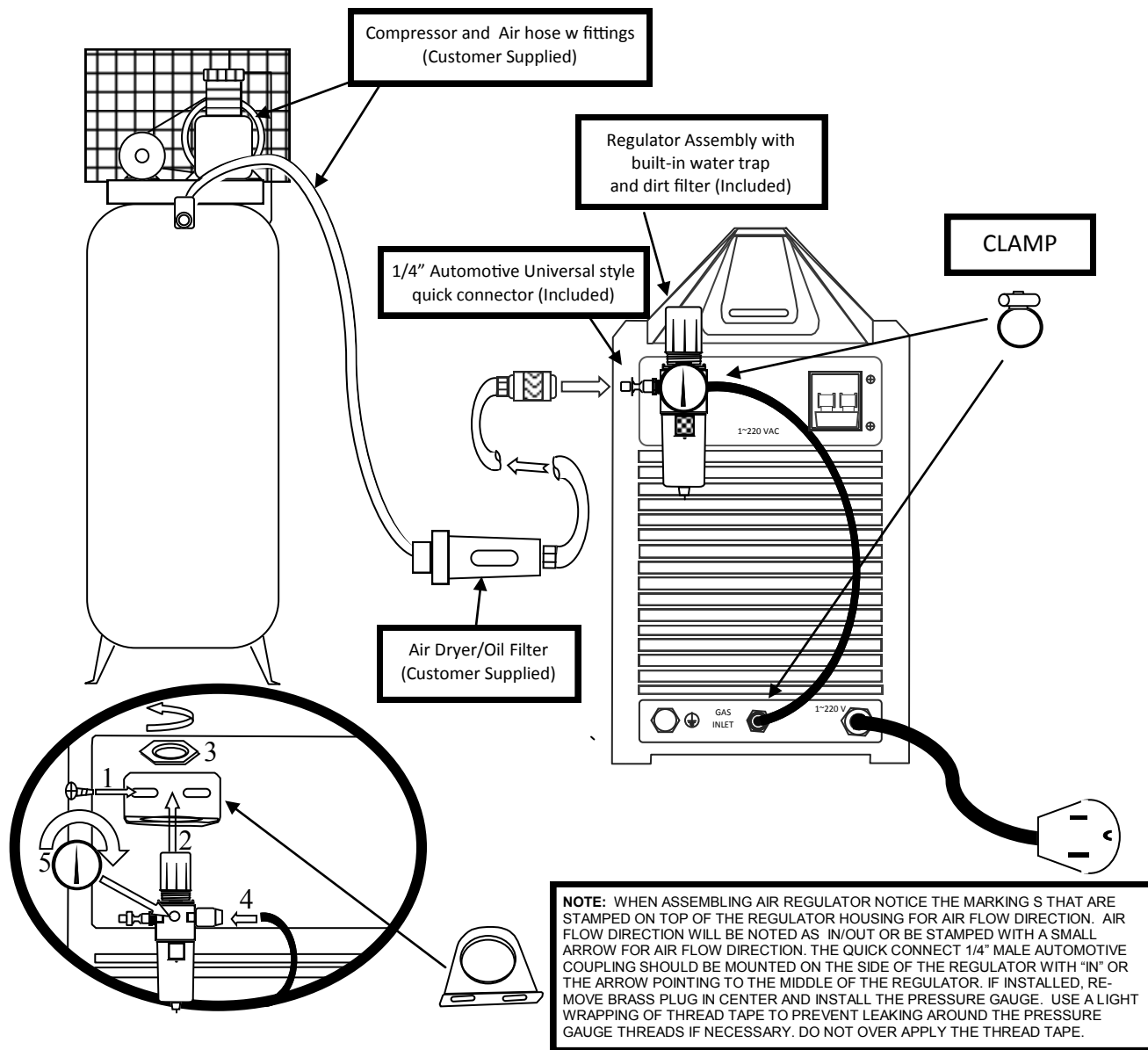

NOTE: A SEPARATE AIR DRYER BETWEEN THE AIR COMPRESSOR AND REGULATOR ASSEMBLY MUST BE INSTALLED. IT SHOULD BE INSTALLED AS CLOSE TO THE POWERPRO UNIT AS PRACTICAL. THIS IS A CUSTOMER SUPPLIED ITEM. THIS WILL REDUCE CUTTING ISSUES SUCH AS SPITTING, POPPING AND RAPID CONSUMABLE WEAR. THE REGULATOR/FILTER THAT IS INCLUDED IS NOT SUFFICIENT TO REMOVE ALL MOISTURE. IT SERVES ONLY AS A WATER TRAP AND FINE SEDIMENT FILTER. ANY AIR COMPRESSOR SYSTEM PRODUCES MOISTURE IN ALMOST ANY ENVIRONMENT REGARDLESS OF HUMIDITY LEVELS. DAILY DRAINING OF THE AIR COMPRESSOR IS RECOMMENDED AS WELL. THE AIR SUPPLIED TO THE PLASMA CUTTER SHOULD BE OF SIMILAR QUALITY USED FOR AUTOMOTIVE PAINTING. DIFFERENT STYLES OF DRYERS ARE AVAILABLE. THE MOST INEXPENSIVE AND COMMONLY AVAILABLE IS THE REPLACEABLE DESSICANT TYPE USED FOR AUTOMOTIVE PAINTING. DAMAGE DONE TO THE TORCH AND THE PLASMA CUTTER (INCLUDING BUT NOT LIMITED TO: SHORTING, CORROSION AND DETERIORATION OF INTERNAL LINES AND COMPONENTS) AS A RESULT OF EXCESS MOISTURE IS NOT COVERED UNDER WARRANTY. ADDITIONALLY, A FILTER SHOULD BE INSTALLED IN-LINE OR AT THE COMPRESSOR THAT WILL FILTER ANY EXCESS OIL OR OIL BLOW-BY FROM THE LINE IF NECESSARY. DO NOT USE WITH OILING SYSTEMS DESIGNED TO AUTOMATICALLY LUBRICATE AIR TOOLS. IT IS ADVISABLE TO USE THE PLASMA CUTTER WITH A NEW AIR HOSE/LINE THAT IS FRESH WITHOUT MOISTURE OR LUBE CONTAMINATION. IF AIR PRESSURE DROPS FROM THE COMPRESSOR TO THE CUTTER MORE THAN 5-10 PSI, OR AIR FLOW IS INSUFFICIENT, INCREASE TO A LARGER SIZE DRYER/FILTER. FAILURE TO USE THE PROPER DRYER/FILTER IS THE NUMBER ONE CAUSE OF CUTTING ISSUES.

SECTION 2

**QUICK SETUP GUIDE: REAR CONNECTIONS FOR TIG / WIRING
(US/Canada)**

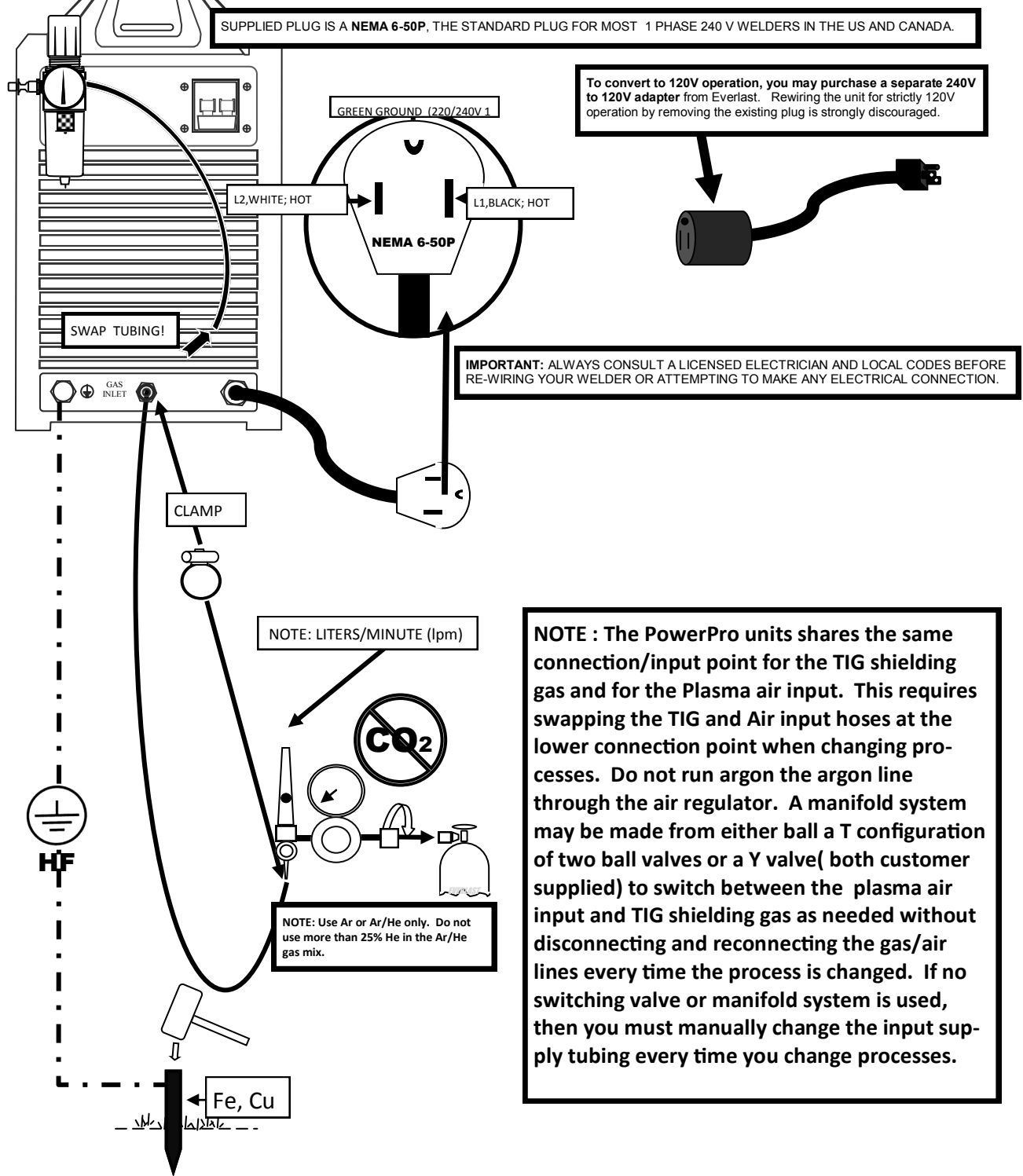

FRONT PANEL FEATURES AND CONTROLS

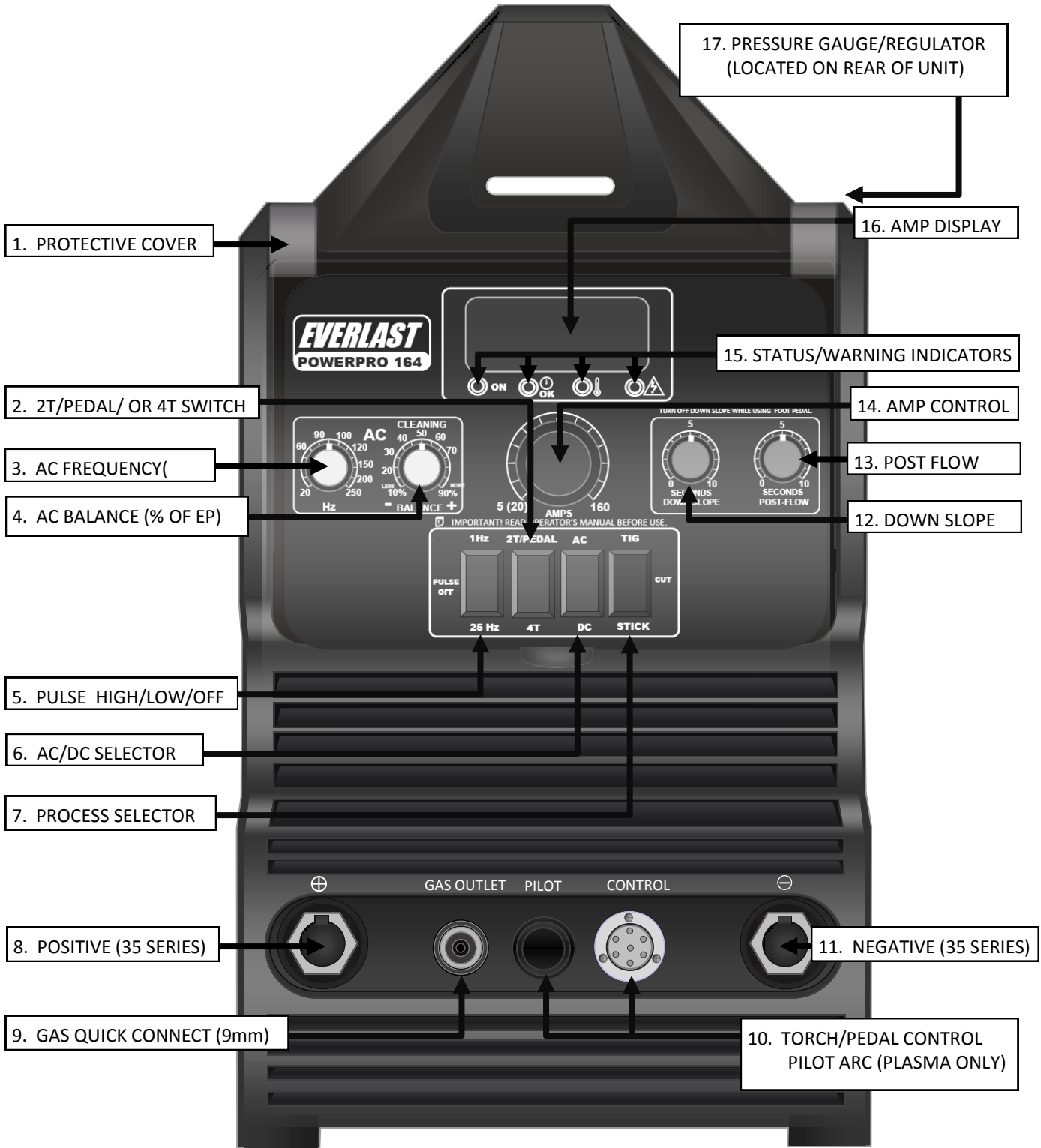

FRONT PANEL FEATURES AND CONTROLS CONTINUED

POWERPRO 164 FEATURES	PARAMETERS	PURPOSE
1. Protective Cover	N/A	Clear hinged cover protects panel from damage. Keep closed during welding operations.
2. 2T/4T Sequencer Switch	2T -Pedal/4T	Used with the torch switch function. Select 2T for simple press and hold operation of the torch switch. Release the switch to cease operation. Select 4T for advanced use of down slope. 1) Press and hold switch to start arc. 2) Release switch to begin welding at normal welding current. 3) Press and hold switch once again to begin downslope. 4) Release switch to terminate the arc. In 4T mode, if the puddle becomes too hot, it can be cooled by lightly tapping the switch to begin downslope and tapping again to restart welding before end current is reached. Setting a long downslope helps improve heat control with this feature. IMPORTANT: For foot pedal use: Select 2T. Be sure to turn the down slope to the minimum setting or the foot pedal will not operate correctly.
3. AC Frequency Control	20-250Hz	Controls the number of times per second that the current alternate in AC mode. To achieve greater arc focus (constriction) and increase puddle agitation while welding in AC mode, increase AC frequency. This allows pinpoint use on thin materials, and helps penetration on thicker materials. Ideal adjustment range is usually 100-150 Hertz. For comparison most transformer welders in the US operate on 60 Hz. Greater results can be achieved through the use of the higher frequency range of this welder. Lower Frequencies will widen and soften the arc but reduce the level of control. WARNING: Increasing the AC Frequency increases the noise level while welding in AC. Wear hearing protection.
4. AC Balance Control	10-90% of EP	Selects the percent of Electrode Positive (EP) used during AC welding to provide cleaning. This divides the amount of time that the AC cycle is in Electrode Positive or Electrode Negative during one full AC cycle. It controls the amount of cleaning and penetration via a ratio to achieve the best balance while welding on AC. When the control knob is rotated left, more Electrode Negative is present and more penetration will be achieved. When the control knob is rotated right, more Electrode Positive is present and more cleaning (cathodic etching) will be achieved. Too much cleaning action will result in tungsten balling or splitting, making a larger tungsten necessary for the same amperage range. Too little cleaning can result in dirty, sooty welds and even a dull weld appearance. NOTE: This is expressed as a percent of full EP Polarity. This unit uses 100% Electrode Positive as the reference, which is just the opposite from some other brands. Using the welder in excess of 50% EP can vaporize the tungsten. It can also reduce the duty cycle of the welder. For most welds, no more than 45% cleaning is needed. Ideally, start with 30% EP for a reference point, and adjust it up or down to achieve best results.
5. Pulse OFF/High/Low	1 or 25 Hz	This pulse control is simplified, offering preset parameters for pulse balance, and pulse amps. Select 1 or 25 Hz, and all other parameters are set automatically. The pulse will offer reduced heat input into the weld. Pulse will reduce maximum penetration however.
6. AC/DC Selector	AC or DC	Select DC output for Steel, Stainless and most metals. Select AC output for Aluminum and Magnesium alloys. NOTE: When in plasma mode turn off pulse. Do not connect foot pedal to operate plasma. While plasma cutting, turn down (off) all 2T/4T controls except post flow. For safest use, use plasma in 2T. Do not flip the process selector switch while cutting or welding or instant damage may result.
7. Process Selector	TIG/Cut (Plasma)/Stick	Select TIG, Stick or Plasma cutting. Do not switch modes while actively welding or cutting or damage to the machine may occur.
8. Positive Connector	35-70 mm ²	Location of the positive terminal connection. Dinse-style connector. (35 Series) For Stick: Torch connection. For TIG: Work Clamp Connection.
9. Quick Connect Gas Outlet	9 mm	Connects the gas to the TIG torch. To connect: Push the torch fitting into the connector until the collar slides forward with a click. To Release: Slide the collar back.
10. Control (TIG and Plasma use) and Pilot Arc (Plasma use only) Connectors	7 Pin and Screw Terminal	Connect the foot pedal or torch switch to control socket to control the welder. Only the foot pedal or torch control connector can be plugged in at one time. If the torch has a torch switch feature, tie the loose connector back and leave it unconnected while using the pedal. Do not use foot pedal with Plasma cutter. The Pilot arc establishes the non cutting arc for the plasma cutter when continuity is not present. Do not fire the torch excessively without close proximity to the metal to be cut. Tighten the thumb screw finger tight only. Do not use the plasma cutter without the wire with the eyelet connected securely to the terminal post.
11. Negative Connector	35-70 mm ²	Location of the negative terminal connection. Dinse-style. (35 series) For Stick: Work Clamp Connection. For TIG: Torch Connection For Plasma: Torch Connection
12. Down Slope Control	0-10 Seconds	Ramps the amps down from welding amp value to allow the weld crater to be filled. Set to 0 while using with the foot pedal. If the downslope is used with the foot pedal, a delayed arc stop or arc flash may occur.
13. Post Flow Control	0-10 Seconds	Sets the amount of shielding gas flow time after arc ends to shield the weld to prevent oxidation and cool the torch. Use .5-1 second post-flow or less for every 10 amps.
14. Main Amp Control	Range Varies	The main amp control function varies range according to process and input. May vary ±3% 220/240V: DC TIG: 5-160 A AC TIG: 20-160 A Stick: 5-130 A Plasma: 20-40 A 110/120V: DC TIG: 5-125 A AC TIG: 20-125 A Stick 5-90 A Plasma: 20-25 A

FRONT PANEL FEATURES AND CONTROLS CONTINUED

POWERPRO 164 FEATURES	PARAMETERS	PURPOSE
15. On/Temperature/ Over Current/ OK to Cut Signal Lights	Indicator/Warning Or Fault	On Indicator: Confirms unit is switched on. Temperature Indicator: Lights up and stops welding output until the welder has cooled within normal limits. Allow 10 minutes before attempting to reset manually by cycling the power switch. If the light does not go out after the cool down period by cycling the switch, or if comes on again when the arc is struck, contact Everlast. Over Current Indicator: Lights up when a voltage /amp surge has surpassed the units capabilities. Eliminate the source of the surge and manually cycle the power switch to reset. If the light remains on after cycling the switch, this may indicate a unit fault created during the over current event. In this case, contact Everlast. OK TO CUT: This light will come on while the plasma cutter is being used when the air pressure has reached an acceptable level to prevent torch and unit damage. When air pressure is below the threshold (35 psi) the light will go out and the circuit will interrupt the cutting until the pressure rises over the threshold and the light comes on again.
16. Amp Display	N/A	Displays maximum selected amps until the weld is started. Displays actual amps while welding. Display may cycle rapidly and randomly after pulse has been turned on. This is normal. The meter "samples" the pulse at a fixed rate and is not synchronized with the pulse. Immediately after the pulse is turned on, a short delay is built in that prevents the display from cycling to allow the pulse to be adjusted. Once the adjustment is finished, pulse will begin to cycle after a few seconds if no input is made.
17. Air Pressure Gauge (Not Pictured, located on the rear of the unit and is combined with the air pressure regulator)	90 psi supply 70-75 psi while Operating	The air pressure gauge should not register more than 90 psi while the plasma torch is not in use. While actively cutting pressure should register between 70 and 75 psi. Change torch nozzle size rather than lowering pressure for low amp cutting. Do not run TIG argon gas through the pressure regulator/pressure gauge assembly. See notes page 21.

REAR PANEL FEATURES AND CONTROLS

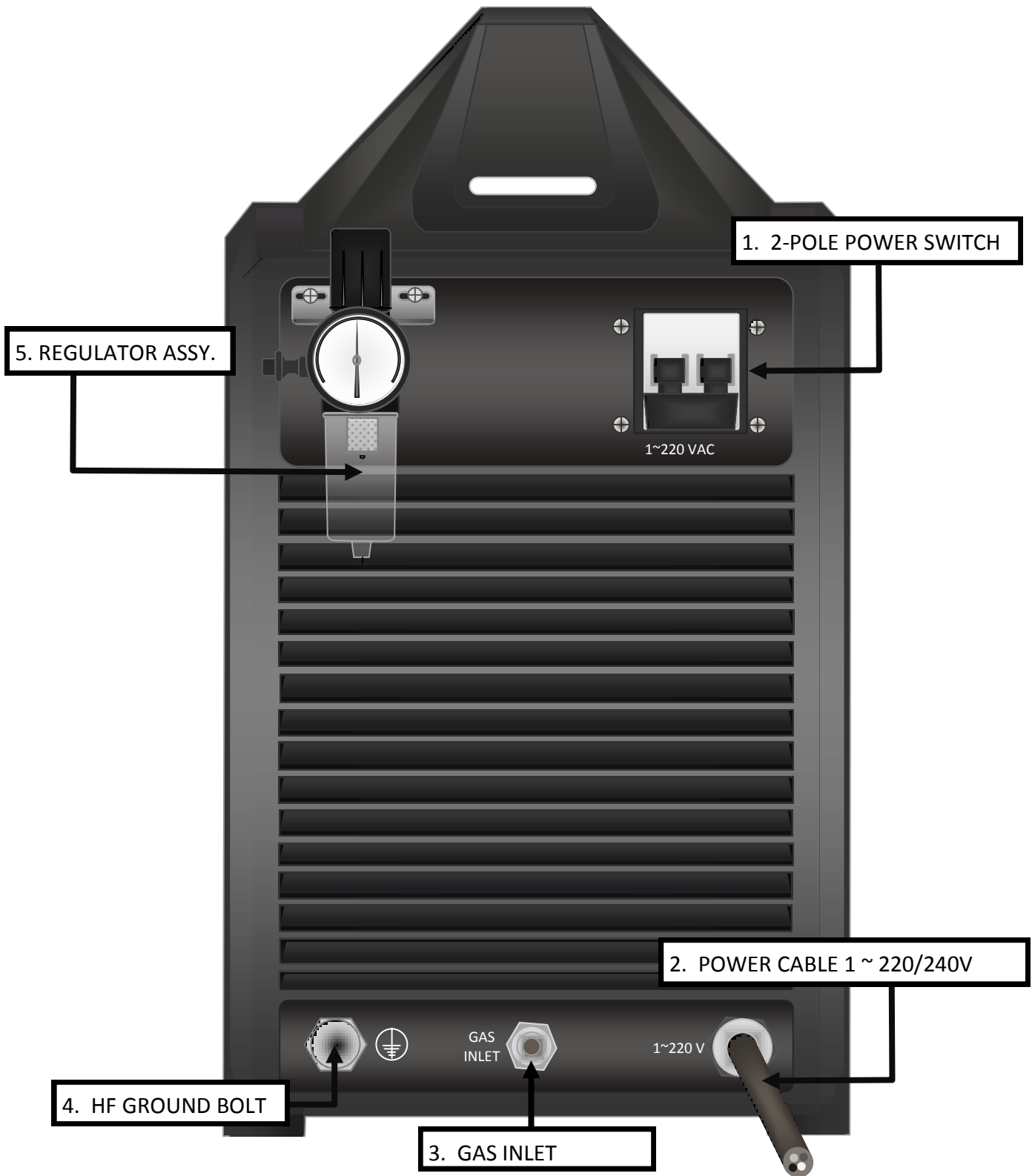

REAR PANEL FEATURES AND CONTROLS CONTINUED

POWERPRO 164 FEATURES	PARAMETERS	PURPOSE
1. 2-Pole Power switch	On/Off	The breaker switch has 2 poles. It serves as the On/Off switch for the welder. Always turn the welder on and off by the switch first before using any disconnect. The Water cooler outlet on the rear remains live after the switch is turned off.
2. Power Cord	110/120V/220/240 V 1 phase, 50/60 Hz.	The unit is prewired with a standard NEMA 6-50 plug. This is the standard plug for welders in the US and Canada. Other countries vary plug configuration as well as input. To operate on 110V/120V purchase the 240 to 120V adapter from Everlast.
3. Gas Input Connection	1/4-5/16"	This is the point where the shielding gas from the regulator connects. The unit is supplied with tubing and clamps which connect this fitting to the regulator. The hose barb design allows universal connection of the welder to almost any regulator or setup found throughout the world. Make sure the tubing slides fully over the connector, then thoroughly tighten the clamp. Use an additional clamp if necessary to prevent leaking. If you suspect leaking, test the connection with a solution of mild soapy water. If bubbles are seen, retighten or reinstall the tubing. While changing processes, the tubing must be swapped. Do not run the Argon gas through the air regulator/filter. A T-fitting or Y-fitting may be placed inline at the connection to leave both argon and air hooked up without having to swap out the lines. This is not supplied by Everlast.
4. HF Ground Bolt	N/A	HF energy can be devastating to surrounding electronic equipment. If the operating environment includes electronic equipment, this connection can serve as a direct path to an outdoor grounded metal rod that is isolated from the main electrical circuit to help bleed off excess HF circuit. All metal parts inside the building should be grounded as well, including pipes, tables, and even metal siding. HF energy has been known to bleed back into the power grid and disrupt electronic devices further down the grid. If the point gap becomes out of adjustment, more HF energy may build up, or even jump across circuitry within the welder. It is recommended that a small, separate ground wire (minimum 14 gauge) be attached to this point while in use.
5. Air Regulator Assembly	90 psi maximum Supply pressure. 70-75 psi operating pressure while cutting	The regulator serves a dual purpose. 1) It controls air pressure for plasma. 2) It filters fine particulates and large drops of water. The regulator is not designed to regulate Argon flow or have argon flowing through it. A separate air dryer must be installed inline to prevent rapid torch and consumable wear (Customer supplied). The regulator assembly is not designed to remove moisture from the air, only large drops of water that may be created in the coupling and uncoupling process. Everlast does not warranty damage caused to torches or consumables by moisture. Residual moisture in the line also can contaminate the system, causing problems while TIG welding. The number one issue experienced with Plasma cutting, with many different symptoms is the presence of moisture in the air line. To adjust the pressure, for cutting, simply pull the knob up until it clicks and rotate it clockwise to increase the pressure, and rotate it counter clockwise to decrease the pressure. To adjust the pressure correctly, adjust the pressure while the air is flowing in post flow mode. If a flow tube for the torch is provided, adjust it so the ball floats in the window as depicted in the torch manual. WARNING: Do not fire torch with the flow tube installed on the torch. Turn Post flow to maximum, fire the torch, then install the flow meter and make adjustments to the air pressure while it is flowing. If no flow tube is provide, adjust pressure to 70-75 psi.

NOTES:

1. The gas input connection should be checked for tightness periodically, especially if the machine is moved or when changing process.
2. Never operate welder on a generator that is not certified by its manufacturer to be "clean" power, which is less than 10% total harmonic distortion. Less than 5% is preferred. Operating the unit on square wave output or modified sine wave generator is strictly prohibited. Contact the manufacturer of the generator for this information. Everlast does not have an "approved" list of generators. But, if the generator is not listed as clean power by its manufacturer, then operation is prohibited. Generators that do not at least meet the operating input requirements of the welder are also forbidden to be used with the welders. Surge amp capability of the generator should equal or exceed the maximum inrush demand of the welder. But the surge capability should not be used as the only factor. The regulator, running output of the generator should match or exceed the running or "rated" demand of the welder. Any damage done by operating the welder on a generator not specified by its manufacturer to be "clean", will not be covered under warranty. This also includes suspect power sources where voltage is below 208 V and above 250 V.

Welder Function Summary and Explanations.

1. *2T/4T sequencer.* The 2T/4T feature allows operation of the TIG welder without a foot pedal. In many circumstances, a foot pedal is not practical for use. So, the 2T/4T function has been created to allow programming of the welder to simulate the activities of the foot pedal while providing more accurate control. The “T” refers to the number of “travels” of the remote switch required to operate the programming of the sequencer. 2T is essentially a “press and hold” operation and all programming is cycled automatically. Releasing the switch begins the final stage of programming. 4T operates differently in the fact that each touch activates a different stage of the programming, allowing for greater control. Also, in 4T, while actually welding at full amps, no finger contact with the switch is required. Following the graphic lines below, you can visually trace the activity and function of each part of the welding cycle. In either 2T or 4T operation the programming can be reset to “upslope” before reaching the end amp stage by pressing the switch once more. See the graphics below for further explanation. The up and down arrows indicate the switch travel direction. NOTE: The PowerPro 164 has fixed start and end amps. It also has fixed preflow and up slope. Downslope and post flow are the only features adjustable on this unit.

2T Torch Operation Effect on Weld Cycle

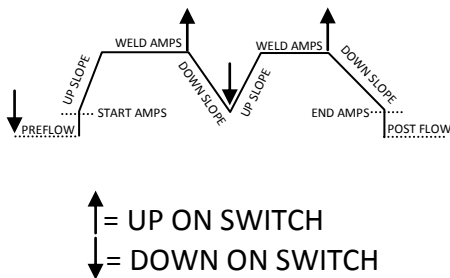

4T Torch Operation Effect on Weld Cycle

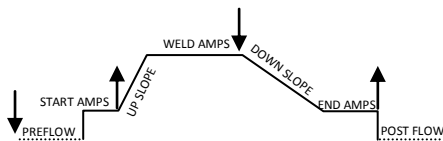

Post-Flow is a feature that works in conjunction with both the foot pedal and the 2T/4T sequencer. Add more post flow time for larger welds.

For Pedal operation, turn Down slope to the minimum setting (0) and select 2T.

2. *AC Frequency.* The AC frequency only applies to the AC mode. Standard transformer welders typically have a fixed frequency of 60 Hz which is essentially the line input frequency supplied by the power company. But with inverters, the AC frequency adjustment is practically limitless due to the IGBT components that create the welding power. Frequency adjustment is useful to help improve the directional control of the arc, and to focus the arc so that a narrower bead profile can be achieved. Also, at higher frequencies, the puddle agitation is greater which improve the breakup of undesirable oxides. A setting of 100-120 Hz is a good starting point. See the graphic below.

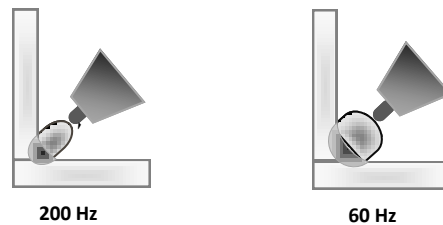

AC FREQUENCY EFFECTS

3. *AC Balance.* The advanced form of AC square wave output is formed by alternating polarity rapidly between electrode negative and electrode positive, creating a wave form that resembles a square “sine” wave when viewed on an oscilloscope. Normally, with standard transformer welders, both standard sine wave and even square wave welders have little or no way to adjust the balance of EN to EP, which results in having to weld with a molten ball at the tip of the tungsten and a less stable arc. Electrode negative (EN) provides penetration in the TIG welding process. Electrode positive (EP) creates a strong reverse flow of electricity that breaks up the weld-resistant oxidation that covers aluminum and magnesium components. EP also places a lot of heat on the tungsten. In a “balanced” wave where both EP and EN are equal in

the side of the weld. Not all weld conditions will be alike, so more cleaning is required at times than others. Similarly, more penetration will be required at times than others. Ordinarily, about 30-35% electrode positive is considered an ideal amount (65-70% electrode negative). This means that more heat is put into the work than is placed on the tungsten. A sharper point can be used. Cleaning is still sufficient at that level. Good results can be achieved with about 30% EP or less. The cleaning action is still visible even at these levels. Ideally, the cleaning action should be adjusted until a small amount of frosting can be seen no more than 1/8" distance from the edge of the weld. If a piece of metal is particularly heavily oxidized or dirty, more cleaning action will be required. If too much cleaning action is used, the tungsten will begin to ball and even may start to burn away. If this much cleaning action is needed, then switch to a larger size of tungsten that can handle the increased heating level. Signs of too little cleaning action while welding aluminum include soot, porosity, and dull looking (scummy) welds. A dedicated stainless steel brush and suitable aluminum cleaner such as acetone should be used before starting any aluminum weld to help break up the heaviest oxide layer so less EP is needed and better penetration can be achieved.

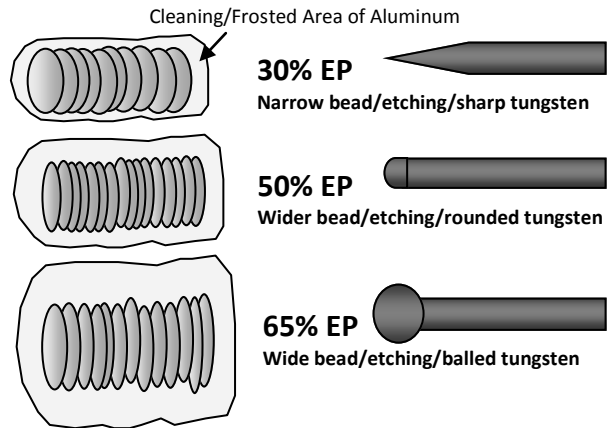

NOTES:

1. Due to the rapid switching of the inverter, High Frequency (HF) is not used except to start the arc. In a transformer welder, the HF would remain on to stabilize the AC arc, but in an inverter, this is not necessary. So, the HF switch refers only to the Start of the arc, and not to AC operation. However to reduce tungsten contamination, you should only operate the AC mode with the HF start selected.
2. The addition of Helium to Argon can increase the welding capacity of the welder and alter the amount of cleaning typically needed. Do not exceed 25% however or arc starts will be difficult and erratic.
3. If arc wandering in AC is a problem, reduce cleaning percent, then if it continues, reduce gas flow and then check for drafts.
4. Yellow-coded AC controls only apply to AC operation, and do not affect the settings on DC.
5. If cleaning lines are excessive at low settings, it is likely not a welder issue, but rather, a speed/heat issue. The longer the electrode remains in the same place, the more the cleaning area will widen. If you find yourself with this issue, try increasing the amperage to travel faster. If overheating is feared, then use pulse to increase forward travel speed to reduce the cleaning lines. You should only suspect a welder issue if adjusting the AC balance to above 40-60% does not begin to ball the tungsten.
6. If tungsten balling is experienced at settings below 40%, make sure that the torch is in the negative connector and that pure tungsten is NOT being used.
7. Do NOT use pure tungsten or Zirconiated tungsten in an inverter to weld in AC or DC mode.

EXAMPLE: AC EP (+) BALANCE

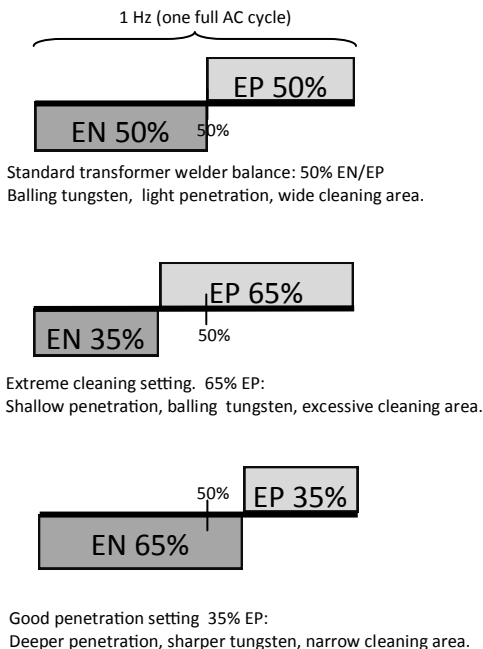

4. *Pulse*. The pulse creates two amp values, a high and a low value that cycle back and forth between each other while welding. The upper amperage is called the “welding amps” (sometimes called “peak” current) and the lower amperage is called “pulse amps” (sometimes called “background” or “base” current). This creates a situation where penetration can be achieved without overheating the metal, particularly on metals that are prone to structural deterioration or burn through. In effect you are creating an average of amps. The PowerPRO 164 has been created with a simple function pulse. The pulse frequency can be selected for either 1 Hz or 25 Hz. The Pulse time on and Pulse amps have been fixed at an optimized setting. This simplified operation allows the user to reduce over all heat input and to improve weld appearance without having to worry about fine tuning the pulse settings.

Do not attempt to use the pulse in plasma or stick mode.

See the example to the right for a basic explanation of pulse components and terminology.

NOTE: The panel will begin to reflect the pulse operation in the digital display soon after switching the pulse function on. The display numbers may appear to be randomized. This is normal, because the display is not synchronized to sample at the same rate that the pulse is pulsing. The display will reflect various amps due to differing sample points. To avoid confusion, set the main amps before selecting the pulse feature.

EXAMPLE 1

Welding Amps: 100 amps,

Pulse Amps: 50%

Pulse Time On: 50%

DC Pulse Frequency: 1 Hz

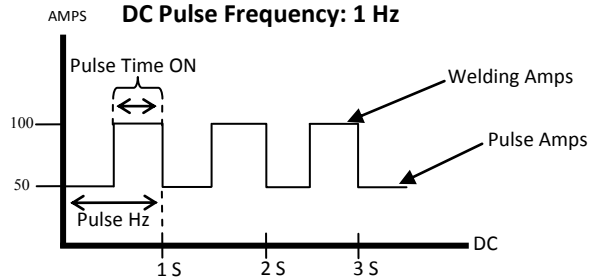

5. *Automatic Arc Force Control/Surge Amp Control.*

When stick welding, arc force is used to help improve performance of the welder with certain metals and welding rods. The arc force boosts current flow to match the demands of arc length and position. As an arc is held shorter, voltage tends to drop so extra amps are introduced to help maintain a steady arc. Surge amps boost the starting amperage briefly to heat up the welding electrode and weld area so the arc starts cleanly, without sticking or porosity. Both controls are inactive while welding in TIG mode. These features are automatically regulated on the PowerPRO 164, but are an intrinsic part of its operation in stick mode.

6. *Foot Pedal. 47k Ω .* Select 2T on the panel. Select the maximum amp value desired on the panel. The foot pedal will only control amps up to the range governed by the main amp control. If more amperage is needed raise the amp level on the panel. The foot pedal also controls both Welding Amps, and Pulse Amps through the ratio established by selecting the pulse Amp % on the panel. Welding with pulse and the foot pedal takes practice, as it will seem the welder is welding at less amps than it is. Always set the panel amps to about 25% more than what is needed. Increasing the amps more than this margin on the panel will reduce the accuracy of the foot pedal by lowering the resolution of the foot pedal. Be sure to turn the start/end amps and up/down slope to the minimum settings or the 2T programming will be active and interfere with pedal operation. The pedal cannot override the 2T amp and slope controls. For more accurate and responsive control, Everlast offers a US made foot pedal available as an additional option. **Do not attempt to control the stick function with the foot pedal.**

8. *Water-cooled torch.* A water cooler is necessary for use with the water cooled torches. These aren't normally necessary with this unit, but many prefer to make a separate purchase of a water cooled torch for comfort's sake. Please note that using a water-cooled torch even briefly without water can seriously and permanently damage your torch. Torches used without water-coolers cannot be warranted unless cleared by Everlast. Everlast carries water-coolers designed to cool the maximum amp capacity of the torches. If you are not able to provide a water cooler or have not purchased a water cooler, you will need to use the stock air cooled (gas cooled) torch provided with the welder, or purchase a air cooled torch that is more suitable.

All consumables should be interchangeable with other brand torches with similar designations. They should be available for local purchase. No special consumables are required. Although a small starter kit of consumables is included, you will need more consumables fairly quickly. **No Tungsten is included with the starter kit. Actual starter kit contents may vary.** Contact Everlast if you desire to purchase an air cooled torch that is complete, ready to go.

9. *DINSE style connector.* Everlast uses a 35-70mm² connector for both negative and positive connectors, which is a standard connector within the welding industry. This is commonly known as a 1/2" or 35 series DINSE-style connector. The connector allows the use of almost any brand or style of TIG torch.

10. *7 pin remote/foot pedal connector.* This 7 pin connector is available from Everlast should it become damaged. See Pin-out reference found near the end of this manual.

11. *Argon quick connect.* This is a 9 mm size quick connect nipple. These are commonly available from Everlast or online sites which carry torches and fittings. Should you need a new one for your torch or damage yours, consult Everlast. Do not use a nipple that is scarred, bent or otherwise deformed. Damage to the female connector may result. Serious leaks may occur.

12. *Low amp starts.* The units have been configured to be able to start and weld at approximately 5(\pm 2) amps in DC stick/tig only. However, to obtain the most stable starts, a slightly higher amp setting may be required, or a smaller tungsten may be necessary. After the arc is started, amps may be reduced to a minimum level. This is accomplished with setting a higher start amp value (2T/4T) or by pressing down more on the foot pedal until the arc stabilizes, then backing the amps down slowly until the arc stabilizes at the minimum selected amps. Minimum start amps in AC is 20 amps. This is still a fairly low value, but to increase weldability on thin materials with this unit, consider increasing AC balance to 40—50%. This may cause the tungsten to ball, and the arc to become slightly unstable, but will put less heat into the material. Decrease AC frequency as well to spread the arc out over a wider area and reduce the concentration of heat.

13. *Argon Regulator.* Note whether the argon regulator is calibrated in lpm, and cfh. (subject to change) Some equipment may be provided in lpm. To roughly convert from lpm to CFH, multiply by 2. This is not 100% accurate, but is close enough not to matter in most situations.

TUNGSTEN PREPARATION

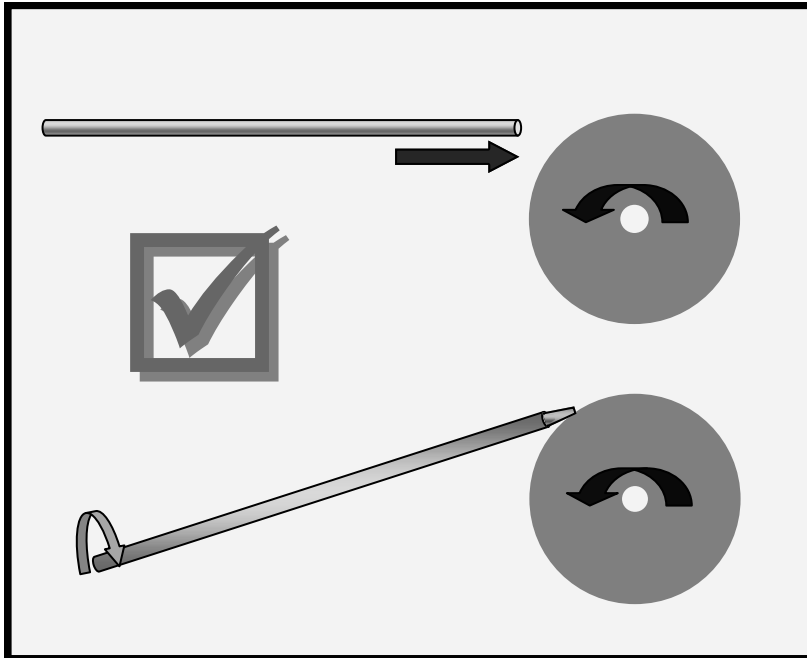

1. Use a dedicated grinding wheel or contamination may result. Do not breath grinding dust! Wear eye protection and gloves.
2. Hold Tungsten firmly.
3. Grind perpendicular to grinding wheel face. Allow tungsten to grind away slowly, creating point.
4. Rotate tungsten quickly as it is being ground to keep point even and symmetrical.

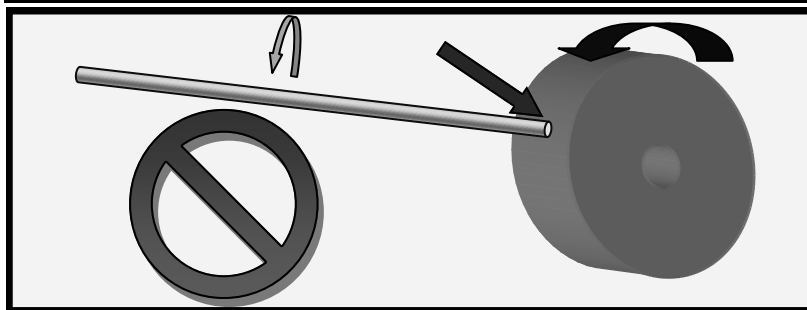

DO NOT GRIND TUNGSTEN PARALLEL TO WHEEL FACE OR AN UNSTABLE ARC WILL RESULT.

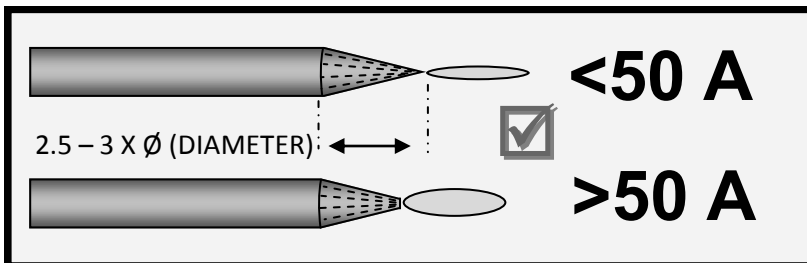

Use a point for low amp use to help control arc. Create a slight truncation on the tip for higher amp use for best arc stability. Grind the tip so that it is 2.5- 3 times longer than the tungsten is wide (Diameter).

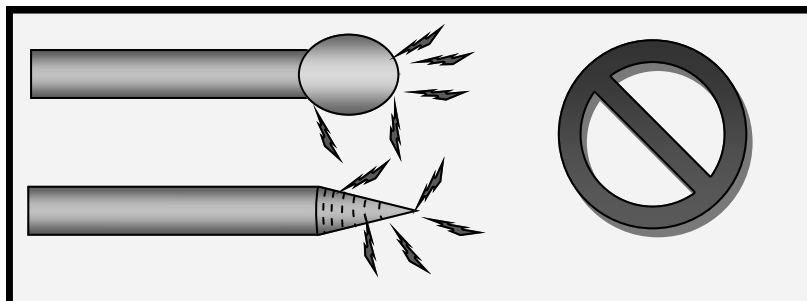

DO NOT BALL TUNGSTEN WHILE USING AC. ERRATIC ARC WILL RESULT. MAKE SURE GRINDING MARKS RUN PARRALEL TO TIP. CONCENTRIC MARKS WILL CAUSE ERRATIC ARC.

NEVER USE PURE (GREEN) TUNGSTEN IN AN INVERTER WELDER TO WELD ALUMINUM. SEE FOLLOWING RECOMMENDATIONS ABOUT TUNGSTEN SELECTION FOUND IN THIS MANUAL ON NEXT PAGE.

HIGH FREQUENCY START TIG OPERATION

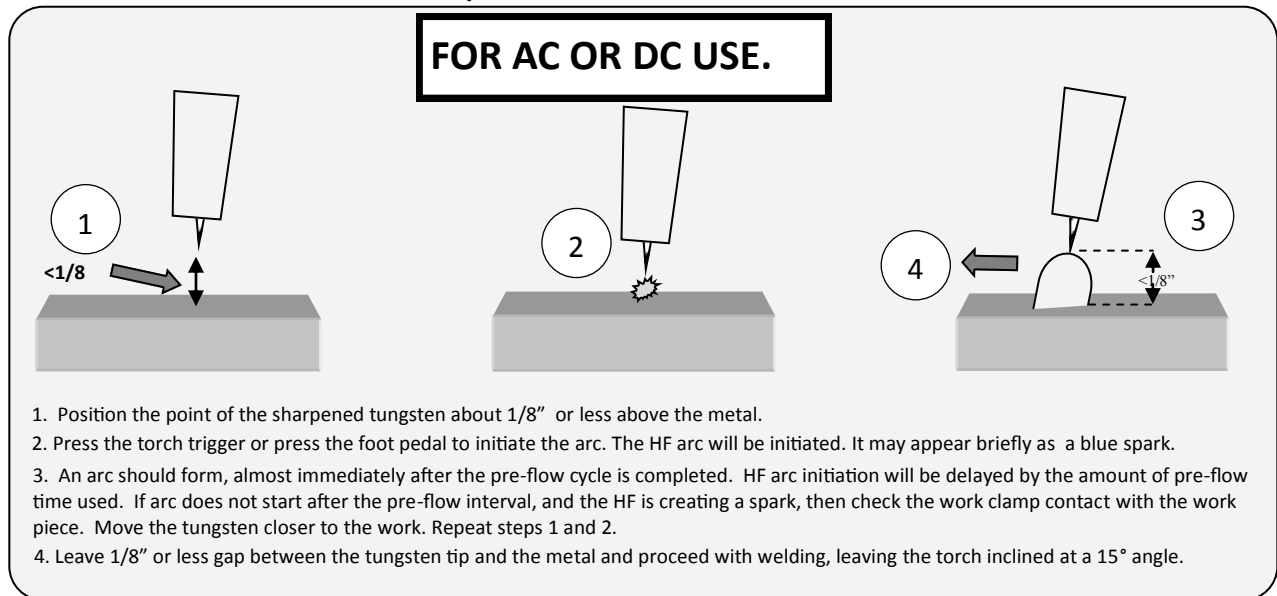

General TIG Arc Starting Steps

1. Turn unit on, allow time for power up cycle to complete its start up process.
2. Select either HF with the HF/CUT/Stick selector switch. Select DC mode with the AC/DC torch switch.
3. Plug in Torch and select 4T or 2T mode with the selector switch **OR** plug in foot pedal and select 2T.
4. If using the torch switch select start/end amps amperage by rotating the knob to increase or decrease amps for starting and ending the weld.
5. If using the torch switch, select up/ down slope time by rotating the knob to increase/decrease the ramp up or ramp down time of the amperage.
6. Adjust amps with amp control knob.
7. Start arc as depicted above.
8. If using 2T, continue to hold the torch switch until you are ready to stop welding. Release the switch. The Arc will then cease.
If using pedal raise foot fully off the pedal and arc will stop automatically.
9. If using 4T, release the switch, after arc initiates. Continue to weld without holding the switch down. To stop, press and release the switch again.

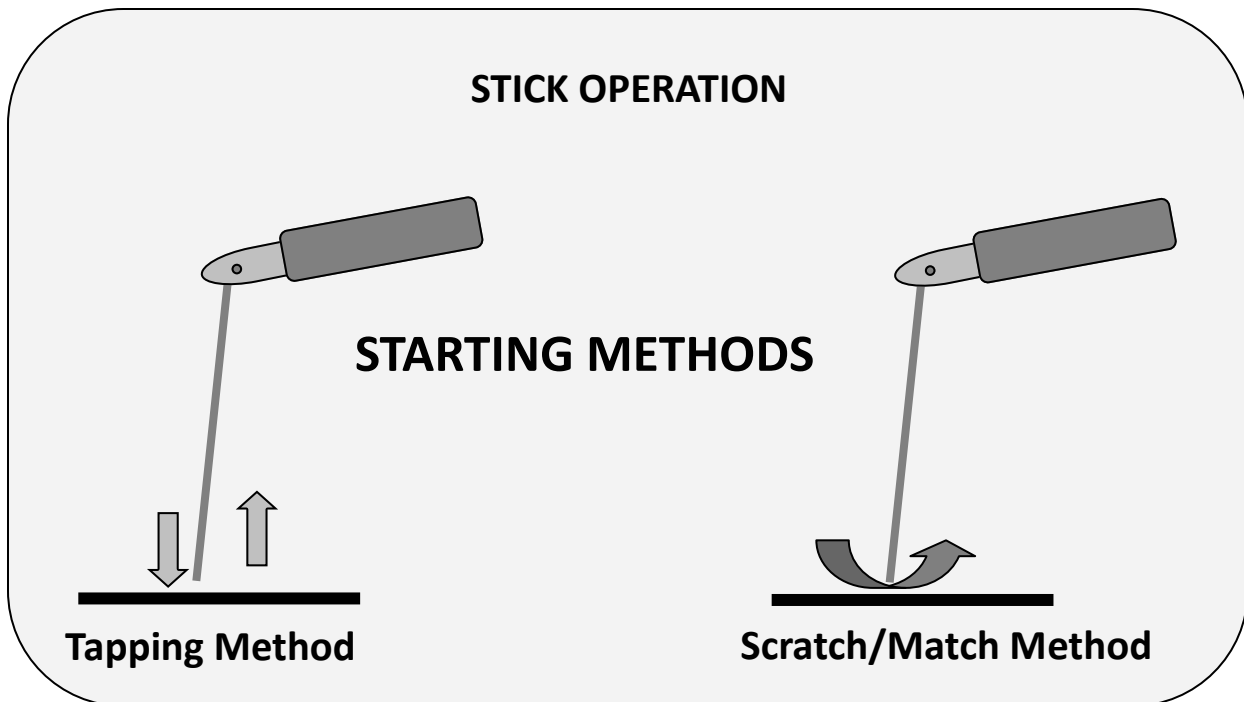

1. Turn on the power switch on the rear of the unit. Allow unit to cycle through its start up program.
2. Select the Stick mode with the HF/Lift Start/Stick selector switch.
3. Make sure electrode holder is hooked into the positive connector and the work clamp is hooked the negative connector.
4. Select the amps desired. Use the electrode diameter selection chart in this manual to determine the approximate range of amps suitable for the rod size selected. Consult the welding electrode manufacturer's recommendation for proper amperage range. Each manufacturer has specific recommendations for its electrodes.
5. Strike the arc with either the tapping method or the match strike method. Beginners usually find that the match strike method yields best results. Professionals tend to gravitate toward the tapping method because of its placement accuracy which helps prevent arc striking outside of the weld zone.

IMPORTANT: Do not weld in the TIG mode with the stick electrode holder still attached.

SECTION 3

BASIC THEORY AND FUNCTION

The design of the blow back start *may* cause a slight delay in the arc as the air pressure must be built inside the torch tubing and head to create the pressure needed to force the electrode off the nozzle seat. This may take up to two seconds. Restarting the arc with the post flow going may not cause a delay. If the torch does not light after 3 seconds, let go of the trigger and press it again. If start/arc is erratic check nozzle and electrode for tightness and wear.

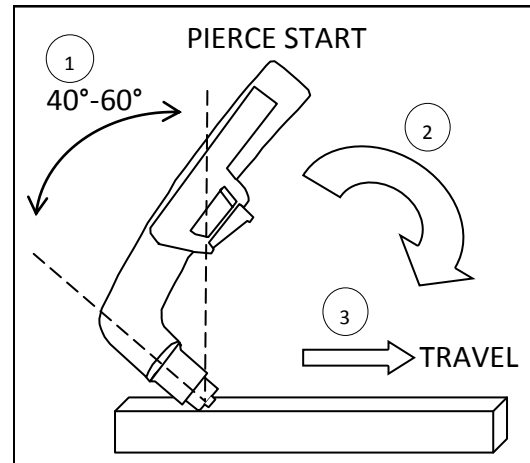
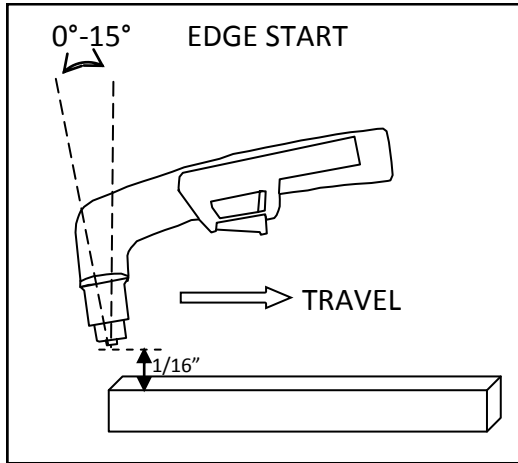

Edge Starts are the best type of start if possible to promote consumable and torch life. This reduces blow back of molten material and allows a smooth gradual start of the cut.

1. Line up the hole on the tip of the electrode on the edge of the cut. Hold torch perpendicular to the cut initially, about 1/16" off the metal. Slide the yellow safety lock and squeeze the trigger. Wait for arc to start.
2. Once the arc starts, wait for the arc to penetrate all the way through the metal.
3. As the torch penetrates its flame all the way through the metal, tilt the torch so there is a slight lead in the flame if metal is thin. If it is thick, keep holding torch in a nearly vertical position.
4. Begin moving the torch in the direction of the cut. Maintain 1/16" standoff height.
5. Move the torch fast enough so the sparks and flame trail from the bottom edge at an angle of no more than 30° and no less than 10° from perpendicular to the metal. Excess angle of sparks/flame indicate too fast of travel speed or practical cut capacity has been reached. Little or no angle indicates too slow of travel speed.

Piercing starts often result in rapid consumable wear and excess blow back of molten metal deposited onto torch and consumables. This should be done only as necessary.

1. Tilt the torch in the direction of travel or toward the side of the metal to be discarded or wasted at a 40° to 60° angle. Slide the yellow safety lock and squeeze the trigger. Wait for arc to start.
2. Once the arc starts, wait for the arc to transfer from pilot arc to the cutting arc.
3. As the torch penetrates it flame at an angle rotate the torch slowly to the vertical position, as the arc penetrates the metal. Tilt the torch from 0°-15° for thin metal cuts, or hold it nearly perpendicular for thicker metal cuts.
4. Begin moving the torch in the direction of the cut. Maintain 1/16" standoff height.
5. Move the torch fast enough so the sparks and flame trail from the bottom edge at an angle of no more than 30° and no less than 10° from perpendicular to the metal. Excess angle of sparks/flame indicate too fast of travel speed or practical cut capacity has been reached. Little or no angle indicates too slow of travel speed.

IMPORTANT: If you use a standoff guide with the torch, it must be adjusted or bent to provide no more than 1/8" standoff, less if possible. Long standoff heights reduce cut capacity and quality. It also promotes rapid consumable wear and can prevent the pilot arc from transferring.

TIP: For longer consumable life do not use the pilot arc unnecessarily.

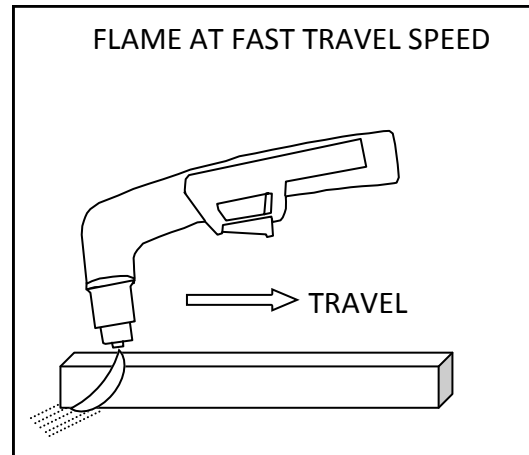
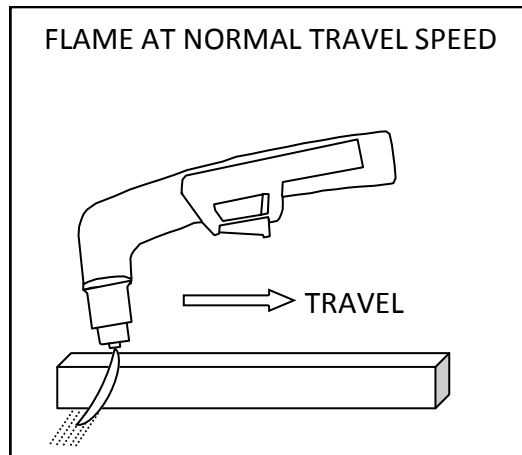

15-30

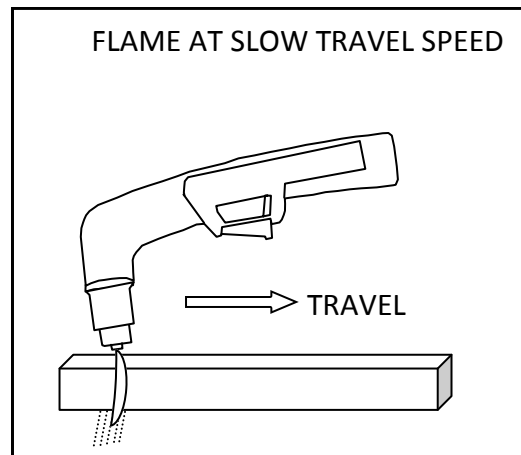

NOTE: When stepping down amps to cut thinner material, you must change to smaller orifice nozzle. Nozzles are offered through Trafimet in different sizes which are appropriate for different amp levels. Too large of a diameter orifice will result in arc instability and a rough cut. Lowering the air pressure below 65 psi to try to get the torch to cut will only result in a lazy, wandering arc.

IMPORTANT: Check consumables regularly for wear and change them out before they are completely worn. Allowing the consumables to wear until they quit working may damage related torch components, creating a more costly repair.

**RESULTS OF CUT AT CORRECT SPEED,
AIR PRESSURE AND TORCH ANGLE**
SMOOTH, EVEN CUT LINES WITH A S REARWARD SWEEP

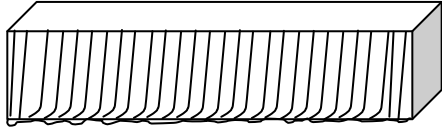

MINIMAL EASY TO CLEAN DROSS

This diagram shows a 3D perspective of a rectangular metal block with a cut. The cut surface is smooth and even, with a slight 'S' curve or rearward sweep. An arrow points to the bottom edge of the cut, which is labeled as having minimal, easy-to-clean dross.

RESULTS OF CUT AT FAST SPEED
ROUGH, DISTINCT CUT LINES SPACED FAR APART

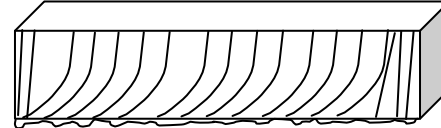

NOTICEABLE SMALL, HARD DROSS

This diagram shows a 3D perspective of a rectangular metal block with a cut. The cut surface is rough and uneven, with distinct, widely spaced lines. An arrow points to the bottom edge of the cut, which is labeled as having noticeable, small, hard dross.

RESULTS OF CUT AT SLOW SPEED
VERTICAL CUT LINES

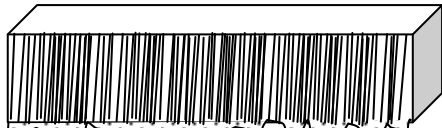

SIGNIFICANT SOFT, POROUS DROSS

This diagram shows a 3D perspective of a rectangular metal block with a cut. The cut surface is characterized by many vertical, closely spaced lines. An arrow points to the bottom edge of the cut, which is labeled as having significant, soft, porous dross.

**RESULTS OF TOO MUCH CURRENT OR
TOO MUCH STAND OFF HEIGHT
(SIDE VIEW)**
MELTED TOP EDGE

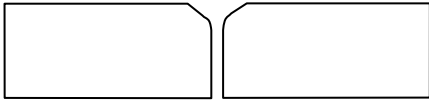

This diagram shows two side-view cross-sections of a cut. The top edges of the cut are rounded and melted, indicating that too much current or too much stand-off height was used.

**RESULTS OF WORN CONSUMABLE OR
LOW AIR PRESSURE
(SIDE VIEW)**
SEVERELY ANGLED CUT AT TOP

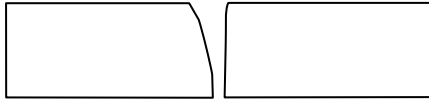

This diagram shows two side-view cross-sections of a cut. The top edges of the cut are severely angled, indicating that a worn consumable or low air pressure was used.

AN EXAMPLE OF CUTTING A LEAD-IN WHEN CUTTING OUT A DISK SHAPED OBJECT

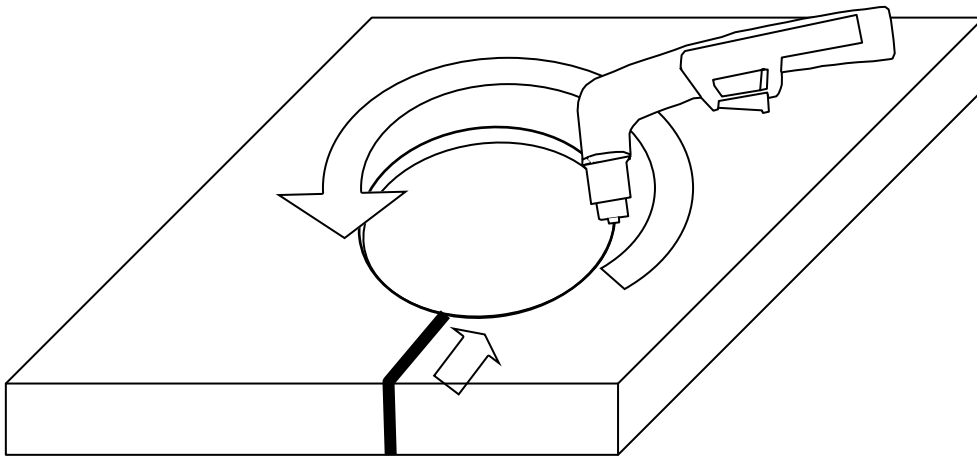

AN EXAMPLE OF CUTTING A LEAD-IN WHEN CUTTING HOLE IN AN OBJECT

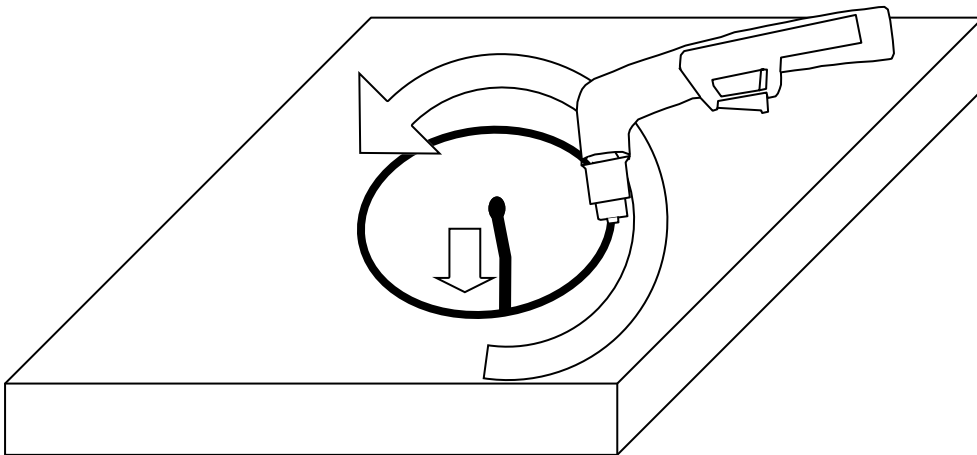

When cutting an object, particularly a pattern shape, where the torch must pierce or re-fire in-line at an intersection of a cut, a lead-in cut should be employed. A lead-in is a cut that is made in the disposable part (also known as a drop) of the object to “lead” into the main part of the cut so that the destructive force of the arc is not directed into the desirable side of the cut itself. Also, all plasma cutters exhibit some angularity or bevel in the cut which is greater on one side than the other. Keep this in mind when cutting an object to size so that too much metal is not accidentally removed.

GENERAL POLARITY RECOMMENDATIONS*

*Follow manufacturer of stick electrode for complete polarity recommendations

PROCESS	TORCH POLARITY	WORK POLARITY
TIG (GTAW)	-	+
STICK (SMAW)	+	-

TIG (GTAW) OPERATION GUIDE FOR STEEL (ALUMINUM)*

*As a general rule, set amperage using 1 amp for every .001" of metal thickness for aluminum. Less is required for DC.

METAL THICKNESS	WELDING AMPS (A)	TUNGSTEN DIA.	Ar FLOW RATE
1-3 mm/.040"-1/8"	40-80 (60-125)	1-2 mm/.040"-3/32"	8-15 CFH /4-7 lpm
3-6 mm/ 1/8"-1/4"	80-200 (125-200)	2-3 mm/ 3/32"-1/8"	15-25 CFH/ 7-14 lpm
6-10 mm 1/4"-3/8"	150-200 (200-250)	3-6 mm/ 1/8"-1/4"	20+ CFH/10-15 lpm.

STICK (SMAW) OPERATION GUIDE

METAL THICKNESS	ELECTRODE SIZE	WELDING AMPS
< 1 mm/.040"	1.5 mm/ 1/16"	20-40
2 mm/.080"	2 mm/3/32"	40-50
3 mm/ 1/8"	3.2 mm/1/8"	90-110
4-5 mm/ 3/16"	3.2-4 mm/ 1/8"	90-130
6-10 mm/ 1/4"-3/8"	4-5 mm/ 1/8"-5/32"	130-200

TUNGSTEN SELECTION GUIDE FOR AN INVERTER

TYPE	PERCENT	COLOR	PROCESS	RECOMMENDATION
Pure	100% Tungsten	Green	AC	NOT RECOMMENDED! Do not use in an inverter.
Thoriated (slightly radioactive)	2% Thorium	Red	AC/DC	YES. Great for all purpose welding. Most economical.
Ceriated	2% Ceria	Orange	AC/DC	YES. Good for low amp use.
Lanthanated	1.5% Lanthanum	Gold	AC/DC	YES. Best alternative to 2% Thoriated. Tough performer.
Lanthanated	2% Lanthanum	Blue	AC/DC	YES. Slight advantage over 1.5% Lanthanated.
Zirconiated	1% Zirconia	Brown	AC	NOT RECOMMENDED! Do not use in an inverter.

NOTE: Thoriated tungsten is slightly radioactive, but is commonly used in the US. Care should be used when grinding so as not to breath the dust. If you have concerns about Thoriated (red) tungsten, choose from Lanthanated or Ceriated tungsten.

EXPANDED VIEW OF TIG TORCH

(Actual appearance may vary slightly from what is listed.)

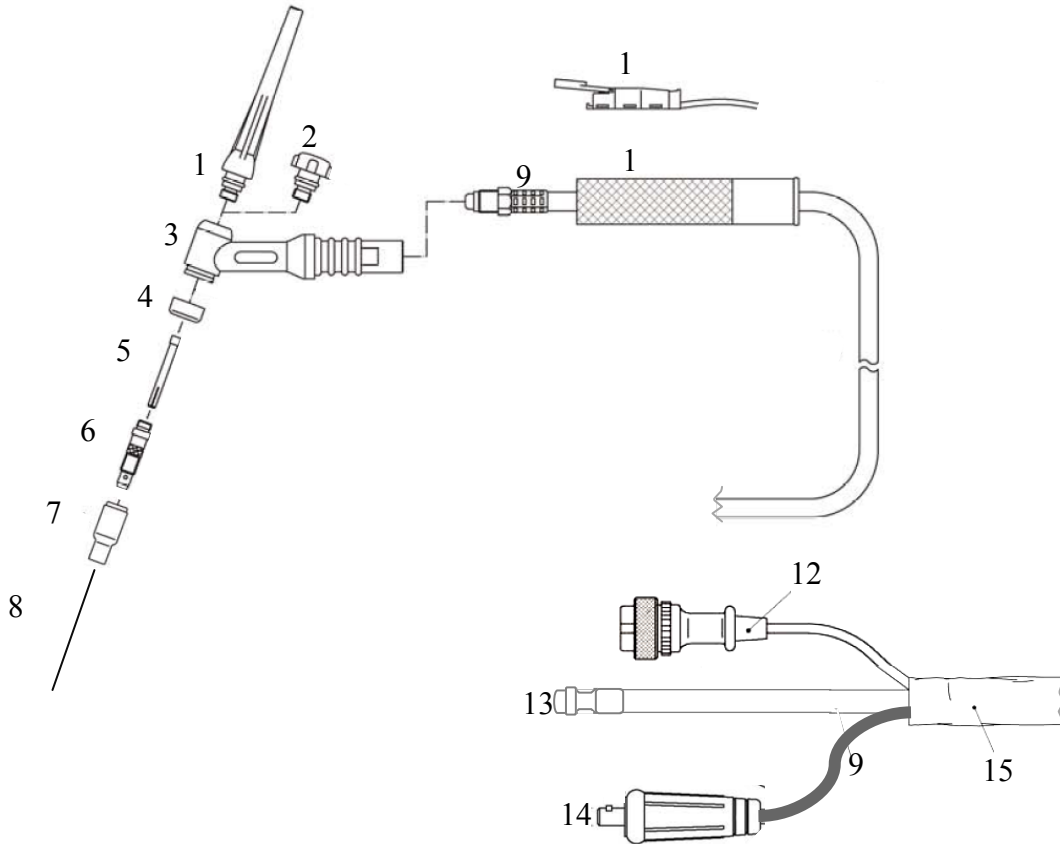

NO.	Parts for Standard 17/26 Series Torch (18 series uses same consumables and basic design is similar, except water cooler line plumbing)	QTY.
1	Long Back Cap with O-Ring	1
2	Short Back Cap	Opt.
3	Torch Head	1
4	Insulator	1
5	Collet 1/16 or 3/32	1
6	Collet Holder	1
7	Ceramic Cup #5,6, or 7	1
8	Tungsten (customer supplied)	0
9	Torch Cable	1
10	Torch Handle (Blue ergo handle std, not pictured)	1
11	Torch Switch (Built into ergo handle, separate on straight handle)	1
12	Torch Switch Connector	1
13	9mm (1/8") b quick connect coupling (male)	1
14	Power Connector	1
15	Protective Synthetic Rubber Cover	1

POWERPRO 205 S-45 PLASMA TORCH**

ERGOCUT S 45*
PLASMA RANGE



TECHNICAL DATA

Voltage class	M
Standard length m	4 • 6
Air consumption	115 l/min
Air pressure	5 bar
Duty cycle 60%	40 A
Air pressure switch	3.5 bar

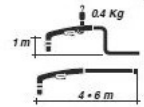

REFRING	PA0165	6
REFRING	PA0167	4
Central	PA0166	6

DECLARATION OF CONFORMITY
The undersigned company Trafimet - Via del Lavoro, 8 - 36020 Castegnero (VI) - Italy - declares that the product identified and described on this page complies with standard EN 60974-7 in accordance with the requirements contemplated by directive EEC 7323 low voltage.



trafimet[®]
your welding partner

ERGOCUT S 45
PLASMA RANGE

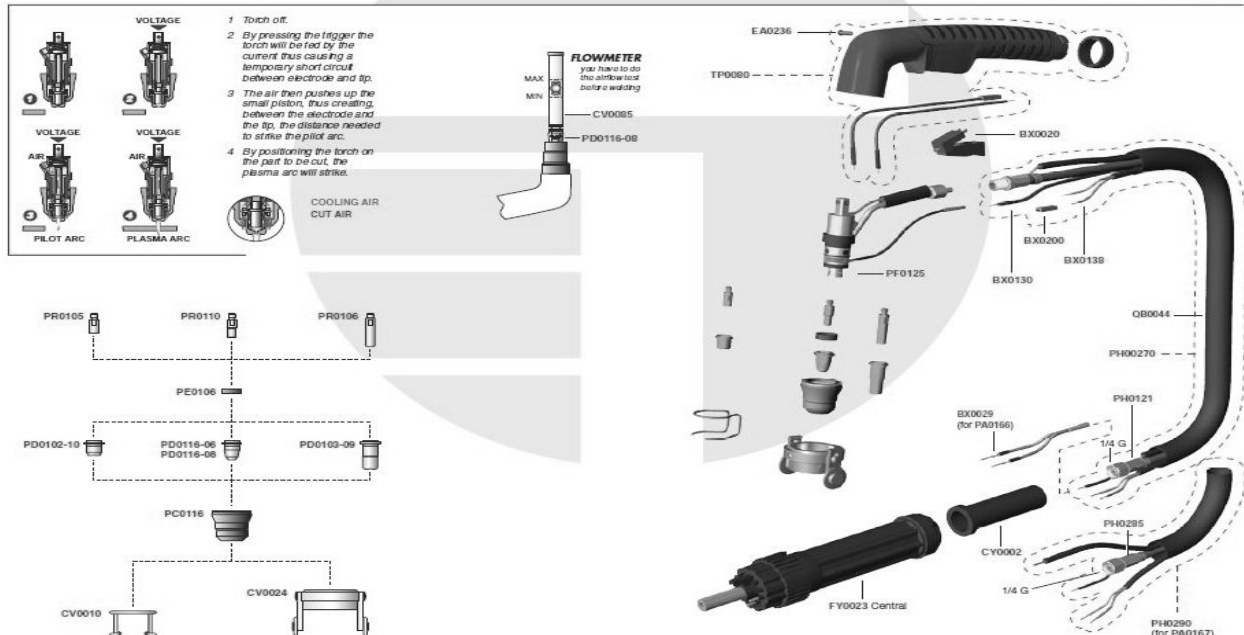

The company reserves the right to modify any products without notice. TRAFIMET spa is the registered owner of all trademarks, patents and models. Copyright © 2007 Trafimet Spa. All rights reserved. First date: 11/04 - EA0630 www.trafimet.com

*Everlast is not the manufacturer of the Trafimet S-75 torch, nor is it affiliated with Trafimet other than its role as an OEM supplier of torches on PowerPRO S-Series units. Trafimet and its logo are a gistered trademarks of Trafimet. Not all items, accessories and parts depicted are available directly through Everlast. These are items supplied through nationwide Trafimet dealers and resalers. Diagram provided courtesy of Trafimet.

**Actual manufacturer of the S-45 torch may vary, but consumables are still considered interchangeable with the Trafimet S-45 model and will function normally.

7 PIN CONNECTOR FOR 47K Ω FOOT PEDAL

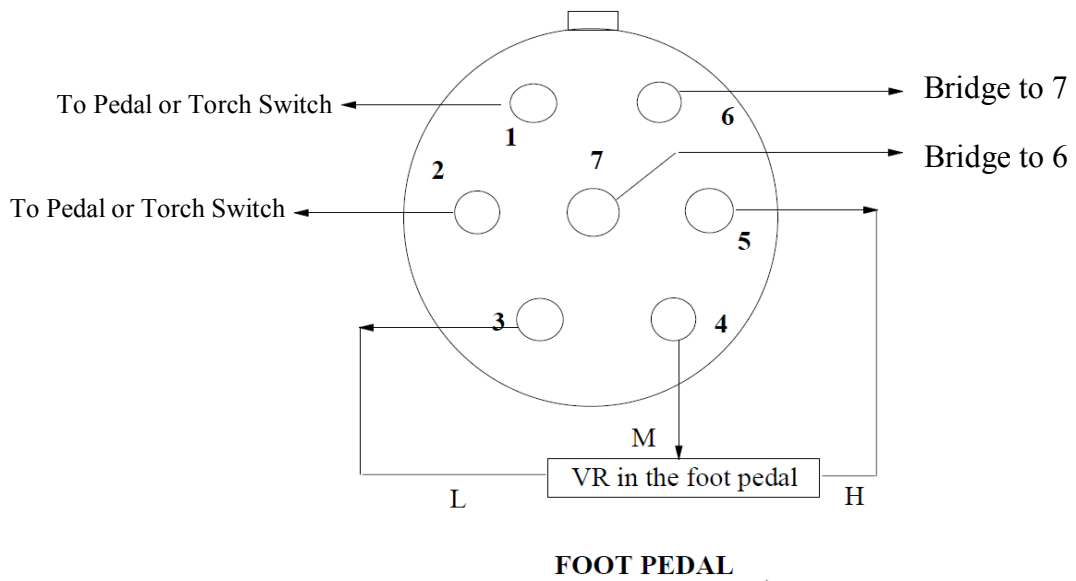

TIG/Stick Trouble shooting:	CAUSE/SOLUTION
Machine will not turn on.	Check cords and wiring in the plug. Check circuit breaker.
Machine runs, but will not weld in either mode.	Check for sound work clamp and cable connections. Make sure work cable and TIG Torch are securely fastened to the Dinse style connector. Reset main power switch if overcurrent light is on. Contact Technical Support.
Arc will not start unless lift started.	Check HF point gap. Set to .035" See addendum or contact Technical Support. Make sure unit is set to HF
Tungsten is rapidly consumed.	Inadequate gas flow. Too small of tungsten. Wrong shielding gas. Use only Ar. Using green tungsten. Use red thoriated or other color. Wrong polarity. Too much AC cleaning.
Tungsten is contaminated, arc changes to a green color.	Tungsten is dipping into weld. Check and adjust stick out to minimum 1/8 inch. Tungsten is melting. Reduce amperage or increase tungsten size.
Porosity of the Weld. Discolored weld color. Tungsten is discolored.	Low flow rate of shielding gas. High flow rate of shielding gas. Too short of post flow period. Wrong TIG cup size. Possible gas leaks internally or externally due to loose fittings. Base metal is contaminated with dirt or grease.
Weld quality is poor. Weld is dirty/oxidized.	Eliminate drafts. Check if there is sufficient shielding gas left in tank. Check gas flow. Adjust for higher flow of gas. Listen for audible click of gas solenoid. If no click is heard, then contact Everlast Support. Clean weld properly, especially in Aluminum. Too short of post flow. Check tungsten stick out.
Over current/Duty cycle LED illuminates. Machine runs, but no output.	Duty cycle exceeded or Over current. Allow machine to cool. Reset main power switch after full cool down period. Make sure fan is not blocked. Check wiring.
Unstable Arc.	Poorly ground or shaped tungsten. Regrind to proper point. Too much AC positive polarity. Reduce balance to 30% or less. Increase AC Frequency.
Other issues.	Contact Everlast support.

SECTION 4**TROUBLE SHOOTING**

PLASMA TROUBLE SHOOTING:	CAUSE/SOLUTION
Air Flows but arc does not start withing 2-3 seconds.	Check consumables for wear and tightness. Check fuse. Check Air Pressure. Sticky or slow spring/piston on torch blow back mechanism. Release trigger and try again. Pre-flow turned on.
Air Flows but arc does not start or spark when nozzle is rubbed on the metal.	Pre Flow is turned on. Fuse blown. Missing swirl ring. Worn or loose consumables. IGBT issue. PCB issue.
OK to cut light is not on. Will not start arc.	Increase air Pressure. Make sure air is connected.
Pilot arc will not light.	Fuse blown.
Pilot arc will not transfer and amps read approximately 25-27 amps while switch is held. (Arc barely cuts or only "scratches" the surface of the metal or cut is extremely slow on thin materials.)	Check work clamp connection. Make sure rust is removed from work clamp contact area. Faulty Clamp. Arc continuity is not being sensed. If these steps do not correct the issue, contact Everlast.
Arc Sputters.	Inadequate air flow or air pressure. Improperly sized nozzle. Decrease size as amps are lowered. Increase air pressure to 70-75 psi while air is flowing through torch. Loose consumables. Check tightness.
Consumables are dirty, smutty looking upon inspection. Premature wear on consumables. Shortened consumable life.	Moisture, oil contamination of consumable. Wrong consumables. Poor quality aftermarket consumables.
Premature wear on consumables. Short consumable life. Uneven wear of consumables, melting of cup.	Moisture, oil contamination of consumable. Excessive pilot arc time. Improper cutting technique. Wrong piercing technique.
Arc will not start. Air will not flow. Machine runs.	Torch cup is loose, safety contact pins dirty or not making contact with cup face. Torch switch wire is loose. Problem with connector. Torch is not properly connected.
Amperage changes constantly, "bouncing" back and forth wildly, randomly.	Pulse turned on. Turn off.
Unstable Arc at lower amps.	Consumable orifice size is too large. Reduce orifice size.
Arc tries to start but irregular, dancing arc and/or arc melts through side of nozzle.	Missing swirl ring, or worn electrode or both. Check and replace. Make sure swirl ring is not cracked.
Arc will try to start if touched to the metal, but no air flow while switch is pressed.	Stuck or dirty solenoid valve. Contact Everlast. Wrong Process selected.
Air flows continuously.	Post flow turned set too long. Preflow is turned on. Solenoid is stuck. Contact Everlast.
Excessively Beveled Cut.	Worn consumables, too high of stand-off height.
Cup and/or nozzle is melting or cracking.	Improper cutting technique/excessive piercing.
Power input circuit breaker trips repeatedly.	Improperly sized circuit. Internal issue. Contact Everlast.
Arc "Blows Out" when ready to cut.	Too high of air pressure. Reduce to 72 psi.
Arc will not stop when switch is released.	Unit is in 4T. Switch to 2T. Torch trigger is stuck.

